

Keywords for SAXS Data in EDF Files

EDF_DataFormatVersion = 2.42

Peter Boesecke

Keywords for SAXS Data in EDF Files	1
EDF_DataFormatVersion = 2.42	1
Peter Boesecke	1
1. General Properties (EDF)	6
Short Description	6
Keywords	7
Types of Header Values	7
String Value	8
Long Integer Value	9
Double Float Value	9
Double Float Value with Unit	9
Time Value	9
2. Data Format Specific (EDF)	9
Header Start Pattern	10
Header End Pattern	10
General Block Header Keywords (EDF)	10
EDF_DataFormatVersion	10
EDF_DataBlocks	11
EDF_BlockBoundary	11
Data Block Header Keywords (EDF)	12
EDF_DataBlockID	12
EDF_BinarySize	13
EDF_HeaderSize	14
EDF_BinaryFileName	14
EDF_BinaryFilePosition	15
EDF_BinaryFileSize	15

3.	Description of Binary Data (EDF)	15
	Keywords	15
	ByteOrder	15
	Compression	16
	DataType	17
	DataValueOffset	19
	N-dimensional Raster Data (Arrays, Images and Volumes) Dim_(n)	20
	DataRasterConfiguration	20
	RasterOrientation	22
	Pixel Coordinates	24
4.	History (SAXS)	25
	Keywords	25
	History-U	25
5.	Description of the Scattering Geometry (SAXS)	25
	Image Coordinates	26
	Reference Systems	26
	Binning	27
	SAXS Geometry	28
	Physical Quantities and Units	30
	Keywords	31
	SaxsDataVersion	31
	Offset_1, Offset_2	31
	BSize_1, BSize_2	32
	PSize_1, PSize_2	32
	Center_1, Center_2	33
	WaveLength	33
	SampleDistance	34
	DetectorRotation_1, DetectorRotation_2, DetectorRotation_3	34
	SampleRotation_1, SampleRotation_2, SampleRotation_3	35
	ProjectionType	35
	Title	37
	Time	37
	Dummy	37
	DDummy	38

6.	Displacement Images	38
	Keywords Prefix	38
	Displaced.....	38
7.	Raw Data (SAXS).....	39
	Info Keywords	39
	DetectorInfo	39
	ExperimentInfo	39
	MachineInfo	40
	OpticsInfo	40
	ProposalInfo	40
	StationInfo.....	41
	SubTitle.....	41
	Detector Keywords	41
	DetectorPosition.....	41
	DetectorName	42
	Multichannel Scaler Keywords.....	42
	HS32Len	43
	HS32C<nn>	43
	HS32N<nn>	44
	HS32Z<nn>	44
	HS32F<nn>.....	45
	HS32Depth.....	45
	Binary Data Keywords.....	46
	HMFrame	46
	HMFile.....	46
	HMStartTime	47
	HMDeltaTime	47
	Keywords to Assign Scaler Numbers to Incoming Photons, Transmitted Photons, Anode Counts and Exposure Time	47
	HSI0	48
	HSI0S	49
	HSI1	49
	HSI1S	49
	HSAnode.....	50

HSAnodeS.....	50
HSTime.....	51
HSTimeS.....	51
Keywords for Explicit Values of Incoming Photons, Transmitted Photons, Anode Counts and Exposure Time.....	52
Version.....	52
Intensity0Monitor.....	52
Intensity1Monitor.....	52
AnodeCountsMonitor.....	52
ExposureTimeMonitor.....	53
Intensity0.....	53
Intensity1.....	54
AnodeCounts.....	54
ExposureTime.....	55
ESRF ID01 Specific Keywords.....	55
Version.....	55
ESRF_ID01_TDC_ResolutionMode.....	55
ESRF_ID01_TDC_Resolution.....	55
ESRF_ID01_TDC_Offset.....	56
ESRF_ID01_TDC_Timeout.....	56
ESRF_ID01_Goniometer_Theta.....	57
ESRF_ID01_Goniometer_Chi.....	57
ESRF_ID01_Goniometer_Chi.....	58
ESRF_ID01_Goniometer_Phi.....	58
ESRF Beamline Specific Keywords.....	59
Version.....	59
ESRF_<IDxx>_<SpecSession>_<Mnemonic>.....	59
8. Backward Compatibility (EDF and SAXS).....	60
Keywords.....	60
HeaderID.....	60
Size.....	60
Image.....	61
Keywords in General Header.....	61
DataKey_<memory>.....	61

9. History.....	62
Version < 1.00.....	62
Version 1.00.....	62
Version 2.00.....	62
Version 2.10.....	62
Version 2.11.....	62
Version 2.20.....	63
Version 2.30.....	63
Version 2.31.....	63
Version 2.40.....	63
Version 2.41.....	63
10. Appendix.....	64
Example of a General Header.....	64
Example of a Data Block Header.....	64
Example of a Data Block Header for Raw Data.....	65

1. General Properties (EDF)

EDF files contain one or more sets of data blocks consisting of an ASCII (characters 1-127) readable header and binary data. The header consists of keyword-value pairs. The header contains only ASCII text and is therefore easily readable. Nevertheless a dictionary is required to make full use of its information. It is not recommended to change the header manually with a text editor because it could change its fixed block length or corrupt the whole data file.

If the file name suffix is .gz , it is assumed that the whole file is compressed with gzip. In this case it needs to be decompressed before processing.

Short Description

The header must start with an opening curly brace '{' and must end after a closing curly brace '}' followed by a line feed '\n'. Alternatively, it can be preceded by a line feed 0x0A or a carriage return line feed 0x0D 0x0A.

In version 2.41 the start pattern of the written files has been adapted to the KLORA file format and the files are now written without leading line feed.

Tab. 1: Standard patterns

Start	0x7B	0x0D	0x0A			'{'	'r'	'n'		
End	0x7D	0x0A				'}'	'n'			

Tab. 2: Alternative patterns (not KLORA conform)

Start	0x0A	0x7B	0x0D	0x0A		'n'	'{'	'r'	'n'	
	0x0D	0x0A	0x7B	0x0D	0x0A	'r'	'n'	'{'	'r'	'n'
End	0x7D	0x0A				'}'	'n'			
	0x7D	0x0D	0x0A			'}'	'r'	'n'		

The header includes all bytes from the first character of the start pattern to the last character of the end pattern. Data can only be written between the start and end patterns.

Files with similar but other start and stop patterns are not considered in this document.

Keywords are not case sensitive. A keyword is always followed by an equal sign that separates it from its value. Each value is terminated by a semicolon ';'. Values are trimmed, i.e. leading and trailing white space is removed. A single leading and a single trailing double prime (") is removed.

Important: An ASCII-zero('\0') is NEVER allowed inside a header, because it is used as an emergency stop if the header end is missing. Curly-braces and semicolons are not allowed inside a header and therefore also neither in keywords nor in values because they are used as control characters. Escape sequences starting with a backslash must be used instead ("\" for "{", "\)" for "}", "\:" for ";", "\\\" for "\" and "\\n\" for a new line (lf or cr/lf depending on the operating system), see section Backslash escape sequences).

For convenience, the header length is limited to multiples of 512 bytes (including start and end pattern). A cr/lf is inserted after each semicolon following each keyword-value pair since it allows the header section to be viewed with standard system utilities on a very wide range of operating systems.. cr's and lf's are generally ignored in values but they should not be used inside numbers.

Keywords

The maximum significant length of a header value is 64 (MaxKeyLen) characters. Keywords are not case sensitive and white spaces are removed.

Types of Header Values

In edfio version 2.41 (2012-07-03) the maximum significant length of a header value has been increased from 512 to 2048 (MaxValLen). String values should not exceed 1024 characters (before 256 characters) (counting also backslash escape sequences (String Value) and final zero('\0') in the output string). Too long header values are truncated. This can lead to truncation of continuation lines when read with edfio versions <2.41.

String Value

A string value is a sequence of ASCII characters that does not contain curly braces or a semicolon. These characters are expressed by backslash escape sequences. Carriage returns ('\r') and line feeds ('\n') are ignored. If the string value contains a backslash followed by an l ('\ l') it is translated to a line feed.

Backslash escape sequences

A single '\' at the end of a string is ignored.

Tab. 3: Transformation of a string value to a string.

string value		string
'\l'	=>	line_feed
'\r'	=>	'\r'
'\n'	=>	'\n'
'\s'	=>	' '
'\t'	=>	'\t'
'\v'	=>	'\v'
'\f'	=>	'\f'
'\{'	=>	'{'
'\}'	=>	'}'
'\:'	=>	':'
'\r'	skipped	-
'\n'	skipped	-
'\;'	end of the string	-
'\<any other character>	=>	<any other character>

Tab. 4: Transformation of a string to a string value

'\r'\n'	=>	'\l'
'\n'	=>	'\l'
'{'	=>	'\{'
'}'	=>	'\}'
':'	=>	'\:'
'\'	=>	'\\'

Long Integer Value

Decimal number with or without a sign (+|-), example +1234567890. Currently only long integer values are used.

Double Float Value

A decimal number with or without a sign (+|-), with a point ('.') as decimal separator and an 'e' as decimal exponent separator, example: -1.234e+2 for -123.4.

Double Float Value with Unit

A Double Float Value can be followed by an underscore and a unit: <value>_<unit>, e.g. 32.5_deg. The following units can be used:

for distances: m (meter)

for angles: deg (degree), rad (radian).

The form <a>_ corresponds internally to an immediate multiplication of <a> with , e.g. 2_deg corresponds to the multiplication of 2* pi/180 and 2_rad and 2_m to the multiplication 2*1. Currently only double float values and double float values with a unit are used.

Time Value

Time values should be written in the following subset of the ISO time notation (YYYY = year, MM: month, DD: day, hh: hour (0-24), mm: minute (0-60), ss: seconds (0-61), ssssss: microseconds ([] optional)):

(1) YYYY-MM-DD hh:mm:ss[.ssssss]

Example: "1998-01-02 12:34:56.000000" for 02-Jan-1998 12:34:56.

Information about ISO 8601 time notation can be found at

<http://www.cl.cam.ac.uk/~mgk25/iso-time.html>.

2. Data Format Specific (EDF)

All data format specific keywords are preceded by "EDF_" and are listed at the top of a header section. "EDF_" keywords that are not listed at the top of a header section are ignored. For convenience some of them are written in a specific order. Data

format specific keywords are only defined in EDF_DataFormatVersion ≥ 2.00 . For all other files default values are used. If the file starts with "\n{\r\nEDF_" it is a version ≥ 2 file. EDF_DataFormatVersion 1 is assumed if the file starts with "\n{".

Header Start Pattern

The start pattern of a header is "\n{" (Version ≥ 2 : "\n{\r\nEDF_". It can be used as a magic pattern to identify the file type).

Header End Pattern

The end pattern of a header is "}\n" (Version ≥ 2 : "\r\n}\n")

General Block Header Keywords (EDF)

Optional, a general header is only defined in Version ≥ 2 . The start pattern of a general header header is "\n{\r\nEDF_DataFormatVersion ". It can be used as a magic pattern to identify a file with general header).

V2.1: The general block header starts with data format specific keywords (starting with "EDF_") and can be followed by application specific keywords (any keyword not starting with "EDF_"). All application specific keywords in the general block header are used as default values. They are used if the keyword is not given in the data block header.

EDF_DataFormatVersion

Description

Obligatory the first keyword in a general header. It describes the version of the data file format

Value

N.mm, where N is a positive number and mm are two numeric characters, e.g. 2.10

Default

1.00

EDF_DataBlocks

Description

Obligatory second keyword in a general header. The value is the number of data blocks in the file.

Value

Positive long integer number larger or equal to 1. If the file contains only a single data block the value can be replaced by "Undetermined".

Default

Undetermined

EDF_BlockBoundary

Description

Optional: The data block length (default: 512 bytes)

Remark: If the data consists of a pure text header file (EDF_BinarySize = 0) and separate binary files (EDF_BinaryFileName = "<binary filename>") the text header file can be written with block boundary 1. The extension of a pure text header file should be ".ehf".

Value

Long Integer Value larger than 0.

Default

512

Data Block Header Keywords (EDF)

EDF_DataBlockID

Description

The value of the data block identifier must be unique in the file. It must be the first keyword in a data block header, if it is not the general block (see General Block Header Keywords).

Value

Format

<sequence>.<class>.<instance>[.<memory>]

<sequence>

Positive or negative long integer value describing the order of the data blocks. In time sequences the sequence number n should usually increase with the start time $t(n)$ ($t(n) < t(n+1)$). The sequence number is independent of the physical order of the data blocks in the file. Usually, the sequence number of the first data block in the file is $n=1$ and the sequence number of each following data block is incremented by 1.

<class>

String describing the data class, currently used: "Image". An image is a n -dimensional array of rastered data and must be described by the keywords "Dim_1" to "Dim_n", "DataRasterConfiguration" and "DataType".

<instance>

"Psd": extension for primary (scientific) data.

"Error": extension for error data

The extensions "FlatField" and "Mask" are reserved, but currently not used.

<memory>

A positive long integer number. It is used in analogy to the "bsl" format to store calibration data or data from other detectors. The extension ".1" must be omitted for memory=1.

Examples

Sequence 1 to 3, primary data in memories 1 and 2

EDF_DataBlockID = 1.Image.Psd ;

EDF_DataBlockID = 2.Image.Psd ;

EDF_DataBlockID = 1.Image.Psd.2 ;

EDF_DataBlockID = 2.Image.Psd.2 ;

Sequence 1 to 3, error data in memories 1 and 2

EDF_DataBlockID = 1.Image.Error ;

EDF_DataBlockID = 2.Image.Error ;

EDF_DataBlockID = 1.Image.Error.2 ;

EDF_DataBlockID = 2.Image.Error.2 ;

Default

no default

Version

2.30 (redefined)

EDF_BinarySize

Description

Obligatory, EDF_BinarySize is equal to the size of the binary block section in bytes that follows after the data block header.

Value

Long Integer Value

Default

0

EDF_HeaderSize

Description

Optional: The length of the header section in bytes.

Value

Long Integer Value

Default

no default

EDF_BinaryFileName

Description

Optional: Name of an **EXTERNAL** file containing the binary data. It must be in the same directory as the EDF file and must be **DIFFERENT** from this EDF file. A path in the filename is ignored.

Value

String Value (Filename without a path)

Default

no default

EDF_BinaryFilePosition

Description

Obligatory keyword that must be given together with EDF_BinaryFileName. Otherwise it is ignored. It describes the start position of the data in the external binary file.

Value

Long Integer Value

Default

no default

EDF_BinaryFileSize

Description

Optional: The size of the data buffer in the external file (currently ignored)

Value

Long Integer Value

Default

no default

3. Description of Binary Data (EDF)**Keywords*****ByteOrder***

Description

This keyword shows whether the more significant data bytes of a single data element are stored before or after the less significant data bytes.

Values

HighByteFirst (default), LowByteFirst

HighByteFirst

The binary data are stored in big endian format, e.g. the two byte integer value 1 is stored in two subsequent bytes as 0x00 0x01 ("Motorola type").

LowByteFirst

The binary data are stored in little endian format, e.g. the two byte integer value 1 is stored in two subsequent bytes as 0x01 0x00 ("Intel type").

Default

HighByteFirst

Compression

Description

This keyword describes the compression type of the binary data block. This compression is independent of the compression of the whole file (suffix .gz).

Remark: It should be distinguished from other types of compressions that are applied to specific data (e.g. 2d data) and that can only be applied after endian correction and reordering. The latter might be called RasterDataCompression (proposal).

GzipCompression and ZCompression have been introduced

Values

None (default), GzipCompression, ZCompression

Aliases

UnCompressed, GzipCompression, ZCompression

Aliases1

NoSpecificValue, Gzip, Z

None

No compression

GzipCompression

The data in the binary block is compressed with gzip.

ZCompression

The data in the binary block is compressed with zlib (see <http://www.zlib.net/>).

Default

None

DataType

Description

The data type of each data element. It defines type and size of data elements. The following data type values are currently defined. Not all data types are in use (see Tab. 3:). The tables Aliases and Aliases1 are used for compatibility. The corresponding names are in each table in the same column and row, e.g. FloatValue, FloatIEEE32 and Float.

Values (recognized and written values)

UnsignedByte	SignedByte	UnsignedShort	SignedShort
UnsignedInteger	SignedInteger	Unsigned64	Signed64
FloatValue	DoubleValue	QuadrupleValue	UnAssigned

Aliases (recognized values, internally used)

Unsigned8	Signed8	Unsigned16	Signed16
Unsigned32	Signed32	Unsigned64	Signed64
FloatIEEE32	FloatIEEE64	FloatIEEE128	UnAssigned
FloatVAX32	DoubleVAX64	FloatConvex32	DoubleConvex64

Aliases1 (alternatively recognized values)

UnsignedByte	SignedByte	UnsignedShort	SignedShort
UnsignedLong	SignedLong	Unsigned64	Signed64
Float	Double	Quadruple	UnAssigned
FloatVAX32	DoubleVAX64	FloatConvex32	DoubleConvex64

Tab. 5: Data type values

value	data size / bytes	data type	comments
Unsigned8	1	unsigned 8 bit integer	
Signed8	1	signed 8 bit integer	
Unsigned16	2	unsigned short	
Signed16	2	signed 16 bit integer	
Unsigned32	4	unsigned 32 bit integer	
Signed32	4	signed 32 bit integer	
Unsigned64	8	unsigned 64 bit integer	only on 64 bit machines
Signed64	8	signed 64 bit integer	only on 64 bit machines
FloatIEEE32	4	32 bit IEEE float	
FloatIEEE64	8	64 bit IEEE float	
FloatIEEE128	16	128 bit IEEE float	currently unused
			currently unused
FloatVAX32	4		currently unused
DoubleVAX64	8		currently unused
FloatConvex32	4		currently unused
DoubleConvex64	8		currently unused

Default

FloatIEEE32

DataValueOffset

Version

2.20

Description

DataValueOffset is used to shift the value range of a short integer data type (1 or 2 bytes) inside the value range of long integer values (machine dependend, usually at least 4 bytes). The actual data value is calculated from the binary data by the following transformation (c-type notation):

(2) DataType Value;

(3) long DataValueOffset;

(4) Value = (DataType) ((long) Data + (long) DataValueOffset);

(5) Value = (float) Data + (float) (long) DataValueOffset ;

(6) Value = (double) Data + (double) (long) DataValueOffset ;

The offset is added at the very end, after endian correction and binary decompression. The result must lie inside the value range of the target data type, otherwise the results are set to the nearest value of that data type.

Only for completeness, DataValueOffset is also defined for floating point data types (equations (5) and (6)).

Values

Long Integer Value

Default

0

N-dimensional Raster Data (Arrays, Images and Volumes) Dim_(n)

Keys are indexed with an underscore followed by a number, e.g. "Dim_3" for the array length *Dim* in direction 3. Keywords ending with an underscore followed by a number are automatically interpreted as a coordinate number and must not be used for other purposes, e.g. for other indexed data, like parameters of a multi channel counter.

Description

The keys Dim_1 to Dim_(n) are used to describe an n-dimensional raster array. Dim_(n) is the number of array elements in dimension n, where n is a positive integer larger than zero. *DataRasterConfiguration* defines the order of the array elements in the linear data buffer and *Dim_(n)* the number of array elements in direction n. If Dim_(J) is found in the header, but not Dim_(J+1) the array has the dimension J. The default for Dim_1 is zero, for all others 1. This allows to read the data array always as a n-dimensional array, e.g. to read a m-dimensional array A[Dim_1, ..., Dim_(m)] as a n-dimensional array A[Dim_1, ..., Dim_(m), 1, 1, ..., 1] by setting the higher indices to 1 or by shortening a m-dimensional array to its first n-dimensions. The values of the key *DataRasterConfiguration* are defined in such a way that this is easily possible.

One dimensional data can be stored in two dimensional arrays with Dim_2 = 1.

Values

Positive integer values (currently limited to Long Integer Value)

Default

The default for Dim_1 is 0, for all others 1.

DataRasterConfiguration

Description

The data raster configuration describes the storage order of array elements in a binary data buffer. The data raster configuration is 1 when a change in a lower index corresponds to a smaller distance between corresponding data elements in the stored data. In other words: "a smaller index runs faster". The default data raster configuration is 1. *DataRasterConfiguration* is only used to convert between different

ways of data storage and not to convert between different coordinate systems. In the second case all indexed keys (keys with an underscore and a number) must be reordered in a similar way as the indices, e.g. when the coordinates are swapped. This must be done in a later step because it requires specific knowledge about the specific coordinate system and its description. The corresponding key is *RasterOrientation*. It is defined similar to *DataRasterConfiguration*.

The data raster configuration of an N-dimensional stored array is defined recursively and has a value between 1 and $2^N \cdot N!$. For example, the elements of a one-dimensional array can either be stored in ascending or in descending order. In the first case the data raster configuration is 1 in the latter case 2.

In the two dimensional case the number of possible data raster configurations is 8. The two first cases are identical to the one dimensional case, only a second index is added after the first index. In the following two cases the storage direction of the second index is inverted. In the four last cases the data elements of the second index appear faster than the data elements of the first index.

The actual data raster configuration of an N-dimensional data array is given by an N-tupel of indices that corresponds to the order from fast to slow in which the data elements are stored, with a negative sign if the direction is inverted. When the second index is the fastest and the direction of the first index is inverted the corresponding tuple would be: (2,-1). This is data raster configuration number 6 (see following figure). The data raster configuration number and the n-tupel are equivalent.

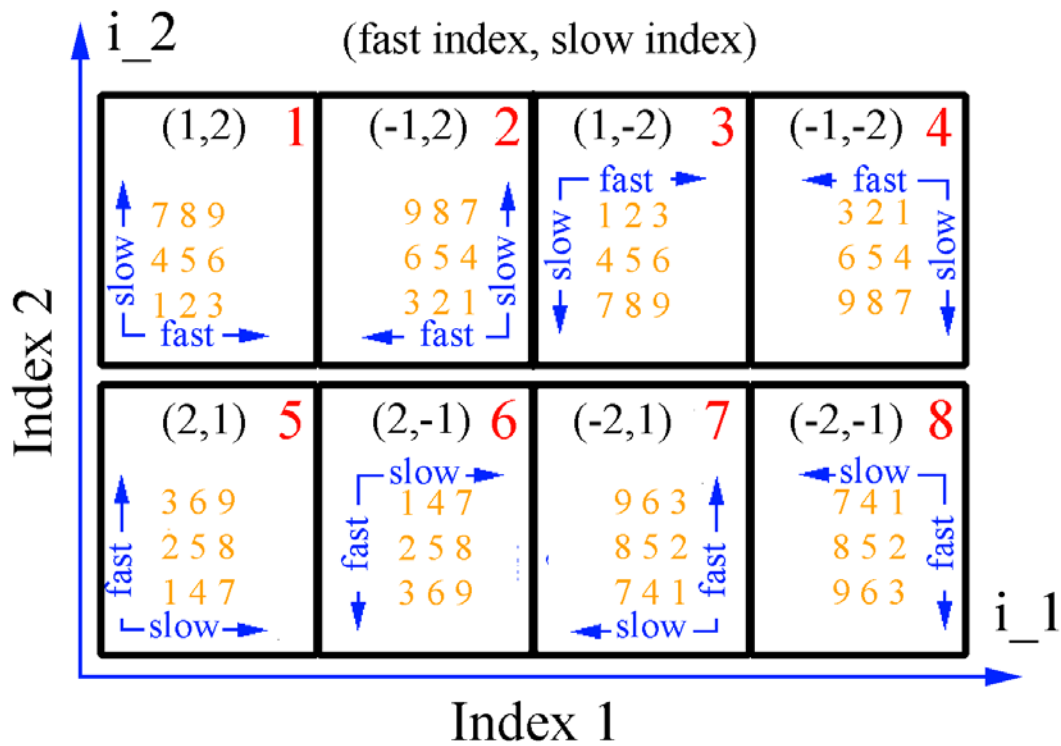

Fig. 1: Data raster configurations for N=2 (two-dimensional image).

Values

Long Integer Values from 1 to $A(N)=2^N * N!$ where N is the dimension. Currently only long integer value are used. For $N>9$ the number of data raster configurations is larger than the value range of long integers. In these cases only data raster configurations from 1 to $2^9*9!$ are possible.

Default

1

RasterOrientation

Description

The keyword RasterOrientation correlates array indices and geometrical coordinates (see Fig. 2:). When data is swapped between different raster orientations all geometrical parameters, like dimension, offset, pixel size and center must also be swapped.

This concept can be extended to more than 2 dimensions.

It should be noted that in the cases 5 to 8 the order of the coordinates are swapped and that the array dimensions must be swapped in the same way. Data with a horizontal dimension 500 and a vertical dimension 600 in raster orientation 1 to 4 have a horizontal dimension of 600 and a vertical dimension of 500 after swapping to raster orientation 5 to 8. Dim_1, Dim_2 and all other index dependend parameters must be changed correspondingly.

Values

Long Integer Values from 1 to $A(N)=2^N * N!$ where N is the dimension.

Default

1

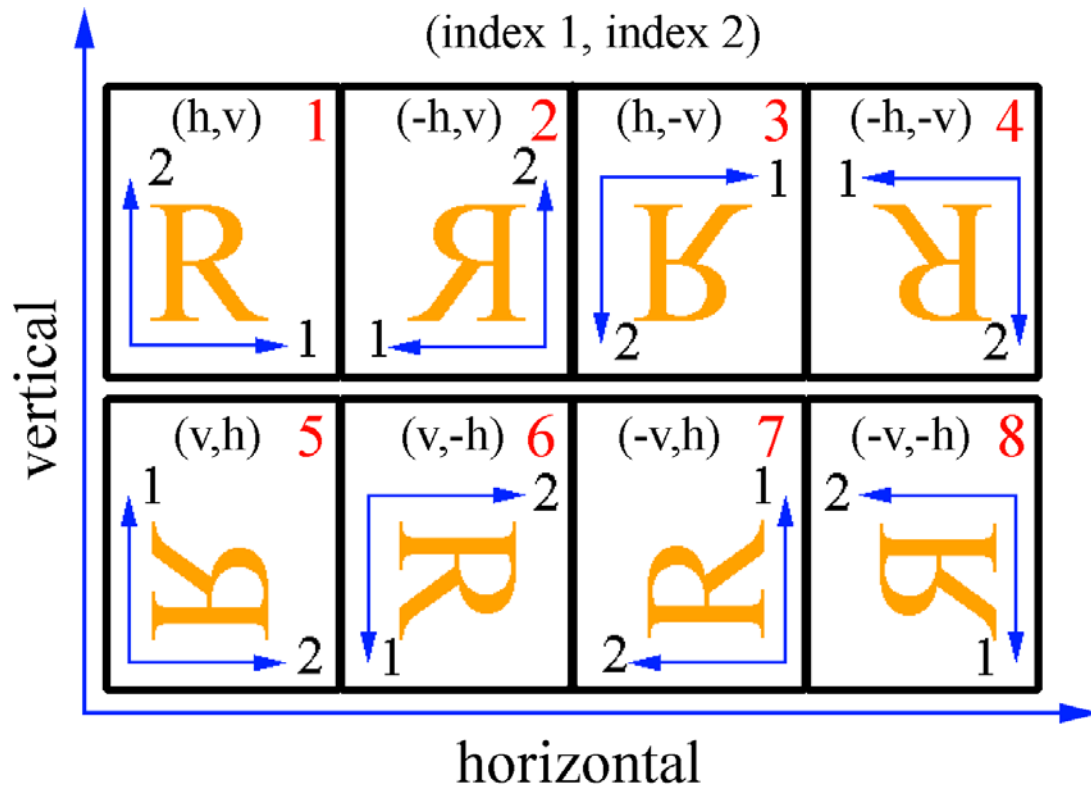

Fig. 2: Raster Orientations for $N=2$ (two-dimensional image). Raster orientation number 1 is used as reference. It is defined as the orientation where the geometrical origin of the image is at the lower left corner, where index 1 corresponds to the horizontal coordinate (x_1) and where index 2 corresponds to the vertical coordinate (x_2). All other orientations are derived from orientation 1 by inverting and transposing the coordinates. In raster orientation 5 index 1 corresponds to the vertical and index 2 to the horizontal coordinate.

Pixel Coordinates

The pixel (or data) coordinate along each direction is expressed by a float type number rather than an integer pixel number. The coordinates start with $p_0=0.0$ at the lower edge of the first pixel (with pixel number 1) and end at the upper edge of pixel number n with the coordinate n . Read access to coordinates outside these limits should not cause an error but should return a dummy values as result. Write access to these coordinates will be ignored.

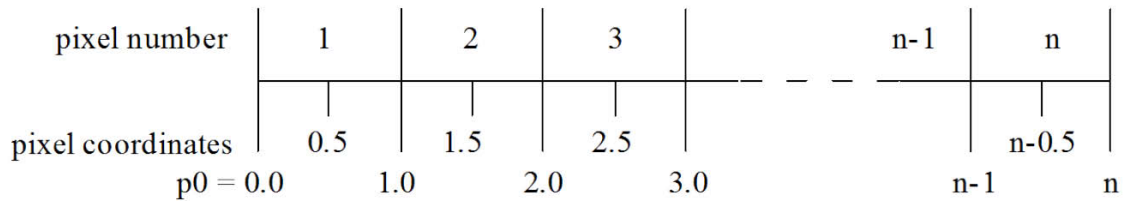

Fig. 3: Pixel coordinates

4. History (SAXS)

In version 2.11 and higher the history of command lines are stored in the file header. They can be used to repeat the calculation.

Keywords

History-U

Description

Each data history keyword is followed by a command line with all options and arguments. The history starts with DataHistory-1. Each call to a function that produces a history line adds a new keyword with the unsigned integer number U incremented by 1. The most recent command line has the highest number U.

The format of the history line is free, but should enable to reproduce the step.

Values

The values are of type String Value.

5. Description of the Scattering Geometry (SAXS)

The geometry is only defined for two dimensional scattering data. One dimensional data can be represented by setting the second index to 1.

Image Coordinates

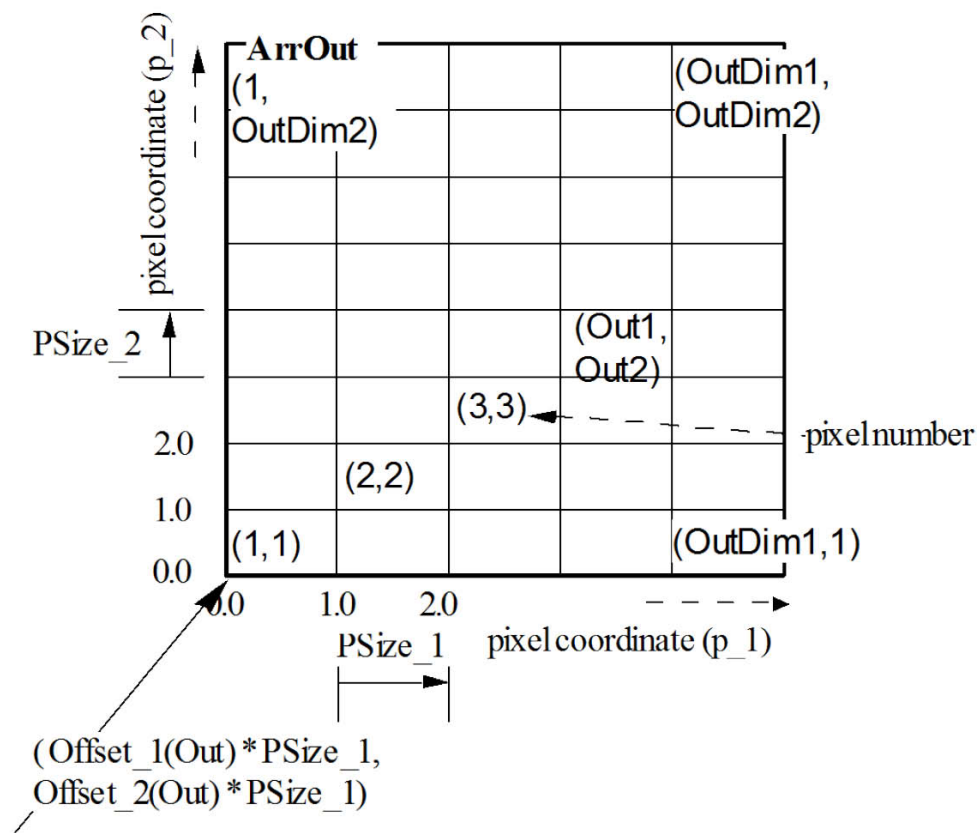

Fig. 4: Two dimensional detector coordinate system. The detector is seen from the sample.

Reference Systems

Currently the following reference system are defined. All reference systems are defined for the same data set.

The simplest description is ARRAY. It uses only the pixel coordinates without any additional keyword.

The standard coordinate system is the IMAGE coordinate system. It consist of the ARRAY coordinates plus an offset.

CENTER coordinates consist of IMAGE coordinates minus the center.

REGION coordinates consist of IMAGE coordinates multiplied with the binning size.

REAL coordinates consist of IMAGE coordinates multiplied with the pixel size.

NORMAL coordinates consist of CENTER coordinates multiplied by the pixel size.

In the SAXS coordinate system the coordinates are oriented around a center. The distance from the center is given by $\tan(2\Theta)/(\text{WaveLength}/\text{WaveLength0})$, where $\text{WaveLength0}=1\text{e-}9$ has been chosen for convenience. For small 2-theta angles the resulting coordinate can be approximated by $s=2\sin(\Theta)/\text{WaveLength}$ [nm], where s is the scattering vector in nanometers. At large scattering angles this coordinate system is still exact, but the coordinates cannot be interpreted directly as scattering vectors. The $\tan(2*\Theta)$ must be converted into $2*\sin(\Theta)$.

The SAXS coordinate system allows the (exact) combination of scattering data from different detectors (small and wide angle), which are mounted perpendicular to the primary beam. Or from the same detector placed at different distances from the sample.

$$\begin{aligned}
 \text{ARRAY coordinate } p &= \text{pixel coordinate} \\
 \text{IMAGE coordinate } i &= \text{array coordinate} + \text{offset} \\
 \text{CENTER coordinate } c &= \text{image coordinate} - \text{center} \\
 \text{REGION coordinate } b &= \text{image coordinate} \times \text{binning size} \\
 \text{REAL coordinate } r &= \text{image coordinate} \times \text{pixel size} \\
 \text{NORMAL coordinate } n &= \text{center coordinate} \times \text{pixel size} \\
 (7) \quad \text{SAXS coordinate } s &= \text{normal coordinate}/\text{sample distance} \times \\
 &\quad (\text{WaveLength0}/\text{WaveLength})
 \end{aligned}$$

Scattering patterns on detectors which are mounted under different angles with respect to the primary beam must be projected into the reciprocal space before they can be combined. This transformation will be called WAXS projection. The transformation requires three additional parameters:

$$(8) \quad \text{DetectorRotation}_1, \text{DetectorRotation}_2, \text{DetectorRotation}_3.$$

WAXS projections are independent of the wavelength, the sample distance and the detector rotations. WAXS projections of different detectors or detector positions can be superposed using SAXS coordinates.

Binning

A binning of the regular raster array by an integer factor B (1,2, ...) in one direction leads to the following parameter transformations:

$$\begin{aligned}
 & p' = p * B \\
 (9) \quad & \text{Offset}' = p_0 \times \frac{1-B}{B} + \text{Offset}/B \\
 & \text{Center}' = \text{Center}/B
 \end{aligned}$$

The detector data is described by the pixel size p [m], an offset [pixel] and a center coordinate. Because the coordinate system was chosen in such a way that $p_0=0.0$ (see Fig. 3:), the transformation of the offset simplifies to:

$$\begin{aligned}
 & p' = p * B \\
 (10) \quad & \text{Offset}' = \text{Offset}/B \\
 & \text{Center}' = \text{Center}/B
 \end{aligned}$$

SAXS Geometry

The principal SAXS geometry is shown in Fig. 5:.. The data is described with an origin in the lower left corner. The detector is seen from the sample ("with the beam"). The data can be treated in one of the reference systems that are shown in Eq. (7).

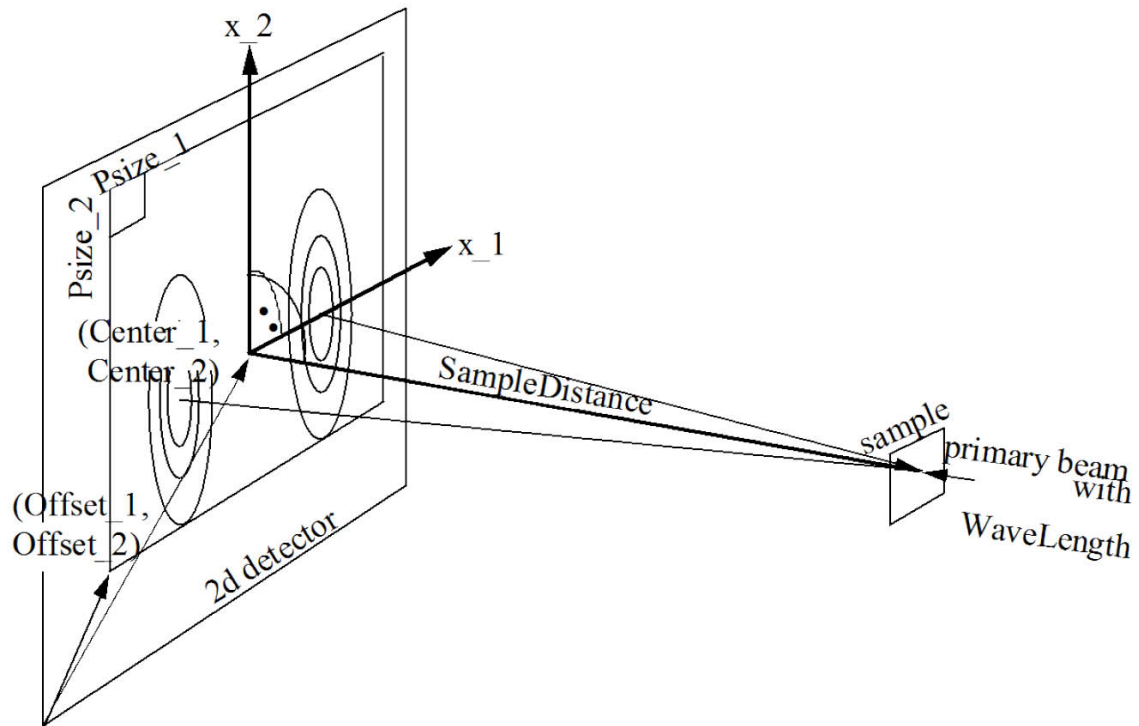

Fig. 5: SAXS coordinate system: The primary beam with a monochromatic WaveLength is coming from the right side and is scattered by the sample. The active detector surface is perpendicular to the beam. The normal incidence point of the primary beam on the detector surface is defined by Center₁ and Center₂. A detector subset area, defined by Offset₁ and Offset₂, is taken into account only. The horizontal and vertical pixel size of the detector is PSize₁ and PSize₂, the distance between the sample and the detector is given by SampleDistance.

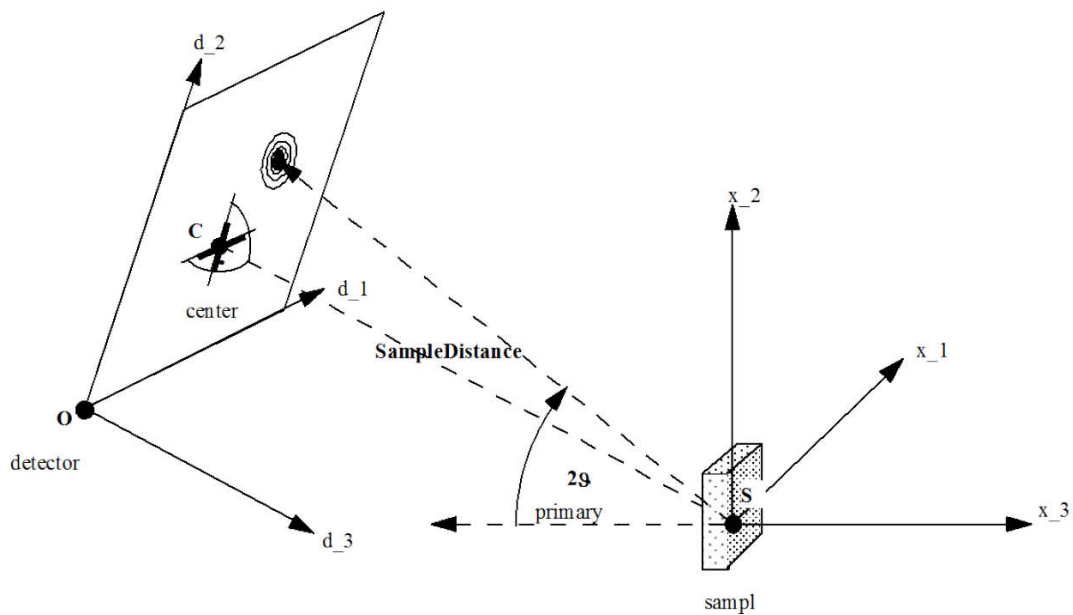

Fig. 6: Extension of the SAXS geometry to an inclined detector geometry. Three additional parameters are required: DetectorRotation_1, DetectorRotation_2, DetectorRotation_3, where DetectorRotation_1 stands for a CCW rotation of the detector plane around axis x_1 , DetectorRotation_2 for a CCW rotation around axis x_2 and DetectorRotation_3 for a CCW rotation around axis x_3 . In this case the center point would be better called PONI (POint of Normal Incidence). The SAXS approximation is still valid around the PONI.

Physical Quantities and Units

If possible the same base unit is used for parameters of the same physical quantity, i.e.

distances in lab space	m (meter)	SampleDistance = 10; WaveLength = 1e-10; PSize = 1e-4;
distances on the image	pixel coordinate	Offset = 10.2; Center_1 = 489.4; BSize = 2.5;
mass	kg (kilograms)	
time	s (second)	ExposureTime = 0.1; DeltaTime = 0.003;
angles	rad (radian)	DetectorRotation_1 = 0.0

It is possible to add explicitly one of the defined units to some type of values (see Double Float Value with Unit). This does not change the default unit that is used when no unit is given explicitly.

Keywords

SaxsDataVersion

Description

Describes the version of the definitions

Values

current version 2.4

Default

0

Offset_1, Offset_2

Description

Offset of coordinate 1 and 2 of the data array as shown in Fig. 4:

Unit

array coordinate (pixel)

Value

Double Float Value

Default

0.0, 0.0

BSize_1, BSize_2

Description

Binning sizes of coordinate 1 and 2. BSize_1 and BSize_2 are pixel sizes that are measured relative to the pixel size of the original image. BSize_1 and BSize_2 are used alternatively to pixel size to combine differently binned images as long as real pixel sizes are not known. They are used to calculate Region coordinates.

Unit

image coordinate

Value

Double Float Value

Default

1.0

PSize_1, PSize_2

Description

Pixel size of coordinate 1 and 2 of the data array as shown in Fig. 4:

Default Unit

meter

Value

Double Float Value with Unit

Default

no default

Center_1, Center_2

Description

Coordinate 1 and 2 of the normal incidence point of the beam on the detector as shown in Fig. 5: If the detector surface is perpendicular to the beam Center_1 and Center_2 are identical to the point where the primar beam would hit the detector.

Unit

image coordinate (pixel)

Value

Double Float Value

Default

no default

WaveLength

Description

Monochromatic wavelength of the beam.

Default Unit

meter

Value

Double Float Value with Unit

Default

no default

SampleDistance

Description

Distance between the sample and the normal incidence point (Center_1, Center_2) of the beam on the detector.

Default Unit

meter

Value

Double Float Value with Unit

Default

no default

DetectorRotation_1, DetectorRotation_2, DetectorRotation_3

Description

Rotation of the detector surface normal relative to the surface normal of the standard detector which is antiparallel to the primary beam. The detector normal at the point of normal incidence (Center_1, Center_2) crosses the sample at SampleDistance.

The rotations are done in counter-clockwise direction around the axes of the unrotated NORMAL coordinate system. The rotations are done in ascending order: DetectorRotation_1 around axis 1, DetectorRotation_2 around axis 2 and DetectorRotation_3 around axis 3. This can be generalized to N dimensions.

Default Unit

The default unit is radian.

radian

Value

Double Float Value with Unit

Default

0

Example

DetectorRotation_1 = 0_deg ;

DetectorRotation_2 = 32.5_deg ;

DetectorRotation_3 = 0_deg ;

SampleRotation_1, SampleRotation_2, SampleRotation_3

In analogy to detector rotations sample rotations are defined by three sample rotations: SampleRotation_1, SampleRotation_2 and SampleRotation_3.

Default Unit

The default unit is radian.

radian

Value

Double Float Value with Unit

Default

0

Example

SampleRotation_1 = 5.576_deg ;

SampleRotation_2 = 23.233_deg ;

SampleRotation_3 = 8.973_deg ;

ProjectionType

The projection type keyword defines the way how the scattering intensities are projected to the image. The default type defines a scattering pattern of a point-like scatterer that is observed with a linear one-dimensional or a flat two-dimensional

detector. This type is called "Saxs" because the scattering vector lengths at small angles 2ϑ around the point of normal incidence (Center) can be linearly approximated by the radial distance r from the center (small angle approximation, $\vartheta \ll 1$: $q = 2\pi \cdot s = 4\pi \cdot \sin(\vartheta) / \lambda \approx 4\pi \cdot \vartheta / \lambda \approx 2\pi \cdot \tan(2\vartheta) / \lambda \propto r$). The second projection type is called "Waxs" because the scattering pattern is projected from the Ewald sphere to a flat plane perpendicular to the incident beam (wave vector k). The radial distances in this projection are proportional to the lengths of the scattering vectors. The azimuthal angles are conserved. The projection is done in such a way that $q = 2\pi \cdot s \propto r$ for any radial distance r from the center.

Description

Currently the following projection types are defined:

Saxs: Scattering pattern that is observed on a plane detector surface as described below (SAXS Geometry). The detector can be rotated. The specific keywords are: Offset_1, Offset_2, PSize_1, PSize_2, Center_1, Center_2, SampleDistance, WaveLength, DetectorRotation_1, DetectorRotation_2, DetectorRotation_3. Pixel distances d_i on a Saxs projection are proportional to distances dx in the laboratory:

$$dx = d_i * PSize$$

Waxs: Projection of a Saxs type pattern to the Ewald-sphere, currently only to a plane that is perpendicular to the primary beam. Rotations to describe inclined geometries may be defined later. Detector rotations cannot be used. The specific keywords are:

Offset_1, Offset_2, PSize_1, PSize_2, Center_1, Center_2, SampleDistance, WaveLength. Pixel distances d_i on a Waxs projection are proportional to distances ds in reciprocal space ($WaveLength0 = 1e-9$, $s = 2 * \sin(\Theta) * (WaveLength0 / WaveLength)$):

$$ds = d_i * (PSize / SampleDistance) * (WaveLength0 / WaveLength)$$

Value

ProjectionType Value: Saxs, Waxs

Default

Saxs

Title

Description

A title of the data block.

Value

String Value with escape sequences (to avoid curly braces and semicolons, see paragraph String Value). Strings longer than MaxValLen (currently 512) are truncated. There are still some subroutines which can only pass 255 characters.

Default

no default

Time

Description

Time at start of the exposure, like 2001-11-25 10:25:03.654321

Value

Time Value

Default

no default

Dummy

Description

A dummy is a value that represents an invalid data point. Zero (0.0) can never be used as a dummy value. All values between Dummy-DDummy and Dummy+DDummy are taken as invalid data points. If $-DDummy < Dummy < +DDummy$ no dummy value is defined.

Value

Double Float Value

Default

0.0 (no dummy)

DDummy

Description

Radius around Dummy to represent a dummy value.

Value

positive Double Float Value

Default

$\max(0.1, 1e-4 * \text{Dummy})$

6. Displacement Images

Each pixel of a displacement image contains the relative displacement of the pixel in the transformed image relative to the input image. Each coordinate requires a displacement image. Because the displacement can be very general the parameters of the transformed image can be different from the input parameters and must be provided explicitly. Keywords that describe the displaced image of the transformation start with the prefix Displaced, e.g. DisplacedCenter_1, DisplacedOffset_1, DisplacedPSize_1, etc.

Keywords Prefix

Displaced

Description

Prefix of keywords in a displacement image that must be used in the displaced image.

7. Raw Data (SAXS)

The following keywords have been defined ad hoc for immediate use at the beamlines ID01 and ID02. They are only used in conversion routines of the form saxs_norm... which convert the raw data into the standard representation.

Info Keywords

All keywords ending with "Info" contain a free format string value about the corresponding item.

DetectorInfo

Description

Info string about detector

Value

String Value

Default

no default

ExperimentInfo

Description

Info string about the experiment in general

Value

String Value

Default

no default

MachineInfo

Description

Info string about machine status or setup

Value

String Value

Default

no default

OpticsInfo

Description

Info string about optical setup

Value

String Value

Default

no default

ProposalInfo

Description

Info string about the proposal

Value

String Value

Default

no default

StationInfo

Description

Info string about the station

Value

String Value

Default

no default

SubTitle

Description

A general description of the experiment, should be replaced by the keyword
ExperimentInfo

Value

String Value

Default

no default

Detector Keywords

Keywords starting with "Detector" are used to describe detector properties.

DetectorPosition

Description

The position of the detector on the optical bench, starting with 0.0 at the end stop close to the sample. The distance between sample and detector is calculated from this by adding a constant.

Value

Double Float Value

Default

no default

DetectorName

Description

Name of the detector (currently free format)

Value

String Value

Default

no default

Multichannel Scaler Keywords

A 32 channel scaler is used to count calibration data during each exposure (incoming photons, transmitted photons, exposure time, anode counts). All keywords starting with "HS32" are related to the 32 channel scaler.

A scaler value is calculated by

$$(11) \quad \text{ScalerValue} = (\text{ScalerCounts} - \text{ScalerZero} * \text{TimerValue}) * \text{ScalerFactor}$$

ScalerZero is used to subtract an offset from a signal of a voltage to frequency converter. The units are as follows: ScalerCounts [counts], ScalerZero [counts/s], TimerValue [s], ScalerFactor [<unit>/counts], where <unit> stands for the physical unit that is measured by the scaler. The keywords for ScalerCounts, ScalerZero and ScalerFactor are shown below.

At least one scaler must be fed with a constant frequency, e.g. 1MHz, and must be used as a timer. The timer value is calculated by

$$(12) \quad \text{TimerValue} = \text{TimerCounts} * \text{TimerFactor}$$

The units are as follows: TimerValue [s], TimerCounts [counts], TimerFactor [s/counts]. The scaler that is actually used as timer is given by the keyword "HSTime" (see below).

HS32Len

Description

Number of scalers, from 1 to HS32Len \leq 32

Value

Long Integer Value

Default

32

HS32C<nn>

Description

ScalerCounts (see eq. (11))

Syntax

All keywords starting with HS32C... are followed by a two digit channel number (HS32C01, HS32C02, ..., HS32C10, ...). The maximum scaler number is given by HS32Len.

Value

Double Float Value

Default

no default

HS32N<nn>

Description

The name of the corresponding scaler

Syntax

All keywords starting with HS32S... are followed by a two digit channel number (HS32S01, HS32S02, ..., HS32S10, ...). The maximum scaler number is given by HS32Len.

Value

String Value

Default

no default

HS32Z<nn>

Description

ScalerZero (see eq. (11)). The zero value of the scaler.

Syntax

All keywords starting with HS32Z... are followed by a two digit channel number (HS32Z01, HS32Z02, ..., HS32Z10, ...). The maximum scaler number is given by HS32Len.

Value

Double Float Value

Default

no default

HS32F<nn>

Description

ScalerFactor (see eq. (11)). The multiplication factor for the corresponding scaler.

Syntax

All keywords starting with HS32F... are followed by a two digit scaler number (HS32F01, HS32F02, ..., HS32F10, ...). The maximum scaler number is given by HS32Len.

Value

Double Float Value

Default

no default

HS32Depth

Description

Double float value that shows the dynamics of the scaler counts. The multi channel scaler has only a dynamics of 24 bits. With an input frequency of 1MHz the counter gets an overflow after approximately 16 seconds. To allow longer counting times the counts of the multi channel scaler are accumulated externally in software. The dynamics of the software counters after $k=0, 1, 2, \dots$ external accumulations is calculated with

$$(13) \quad \text{HS32Depth} = (\ln(k+1)/\ln(2.0)) + 24.0$$

With HS32Depth the maximum scaler count is given by

$$(14) \quad \text{max_count} = \exp(\ln(2)* \text{HS32Depth})$$

Value

Double Float Value

Default

24.0

Default

no default

Binary Data Keywords

All keywords starting with HM (Histogramming Memory) are related to the binary data which were originally data from a histogramming memory for a multiwire proportional chamber.

HMFrame

Description

Frame number of the binary data in HMFile, starting with 1

Value

Long Integer Value

Default

no default

HMFile

Description

File name and path of the binary file that was originally created by the acquisition program.

Value

String Value

Default

no default

HMStartTime

Description

Absolute start time of the experiment (currently still in unix date notation)

Value

Time Value

Default

no default

HMDeltaTime

Description

Relative start time in seconds of the exposure of this image relative to the absolute start time of the experiment (see Default

no default

HMDeltaTime).

Value

Double Float Value

Default

no default

Keywords to Assign Scaler Numbers to Incoming Photons, Transmitted Photons, Anode Counts and Exposure Time

The following keywords assign scalers to specific measurements. Each value can be measured by a primary and a secondary (alternative) scaler. If a scaler is not defined or used the value after the keyword is 0.

The input frequency of the secondary scaler must be a divided frequency of the primary scaler. The calibration factors and zero values must be correctly set for both scalers.

If an alternative scaler exists it is checked for an overflow of the primary scaler. The maximum allowed value of the primary scaler (without subtraction of the zero value) is given by

$$(15) \quad \text{MaximumScalerValue}' = \text{ScalerFactor} * \exp(\ln(2) * \text{HS32Depth})$$

The scaler value without zero level subtraction (') is given by

$$(16) \quad \text{ScalerValue}' = \text{ScalerFactor} * \text{ScalerCountsI}$$

$$(17) \quad \text{ScalerValueS}' = \text{ScalerFactorS} * \text{ScalerCountsS}$$

If the scaler value of the secondary scaler (ScalerValueS') is larger than 99% of MaximumScalerValue' the value is calculated from the second scaler, otherwise from the primary scaler.

HSI0

Description

Scaler number of the I0 monitor (flux before sample) (1 .. HS32Len). The I0-value is the number of photons in the primary beam during the exposure.

Unit of ScalerValue

#photons

Value

Long Integer Value

Default

0

HSIOS

Description

Scaler number of the alternative I0 monitor (flux before sample) (1 ... HS32Len)

Unit of ScalerValue

#photons

Value

Long Integer Value

Default

0

HSII

Description

Scaler number of the I1 monitor (flux after sample) (1 .. HS32Len)

Unit of ScalerValue

#photons

Value

Long Integer Value

Default

0

HSIIS

Description

Scaler number of the alternative I1 monitor (flux after sample) (1 ... HS32Len)

Unit of ScalerValue

#photons

Value

Long Integer Value

Default

0

HSAnode

Description

Scaler number of the anode pulse counter

Unit of ScalerValue

#counts

Value

Long Integer Value

Default

0

HSAnodeS

Description

Scaler number of the alternative anode pulse counter

Unit of ScalerValue

#counts

Value

Long Integer Value

Default

0

HSTime

Description

Scaler number of the time counter

Unit of ScalerValue

seconds

Value

Long Integer Value

Default

0

HSTimeS

Description

Scaler number of the alternative time counter

Unit of ScalerValue

seconds

Value

Long Integer Value

Default

0

Keywords for Explicit Values of Incoming Photons, Transmitted Photons, Anode Counts and Exposure Time

Version

2.10

Intensity0Monitor

Description

Name of the I0 monitor (beam intensity monitor before the sample)

Value

String Value

Default

no default

Intensity1Monitor

Description

Name of the I1 monitor (beam intensity monitor after the sample)

Value

String Value

Default

no default

AnodeCountsMonitor

Description

Name of the anode counts monitor

Value

String Value

Default

no default

ExposureTimeMonitor

Description

Name of the exposure time monitor

Value

String Value

Default

no default

Intensity0

Description

Integrated number of photons in the primary beam before the sample during the exposure.

Unit

#photons

Value

Double Float Value

Default

no default

Intensity1

Description

Integrated number of photons in the primary beam after the sample during the exposure. Attention, the ratio Intensity1/Intensity0 can be larger than the sample transmission if only a part of the primary beam hits the sample.

Unit

#photons

Value

Double Float Value

Default

no default

AnodeCounts

Description

Integrated number of anode counts during the exposure.

Unit

#counts

Value

Double Float Value

Default

no default

ExposureTime

Description

Integrated exposure time

Unit

seconds

Value

Double Float Value

Default

no default

ESRF ID01 Specific Keywords

Version

2.10

ESRF_ID01_TDC_ResolutionMode

Description

Internal code of the time to digital converter for its resolution mode

Value

Long Integer Value

Default

no default

ESRF_ID01_TDC_Resolution

Description

TDC resolution in seconds

Unit

seconds

Value

Double Float Value

Default

no default

ESRF_ID01_TDC_Offset

Description

TDC offset in seconds

Unit

seconds

Value

Double Float Value

Default

no default

ESRF_ID01_TDC_Timeout

Description

TDC time out in seconds

Unit

seconds

Value

Double Float Value

Default

no default

ESRF_ID01_Goniometer_Theta

Description

Theta angle of the esrf id01 goniometer

Unit

degree^Σ (radian)

Value

Double Float Value

Default

no default

ESRF_ID01_Goniometer_Chi

Description

Chi angle of the esrf id01 goniometer

Unit

degree^Σ (radian)

^Σ This parameter is not written any more in SaxsDataVersion \geq 2.4. Originally it was written in degree. If used again, it must be written in radian or must be followed by a unit.

^Σ This parameter is not written any more in SaxsDataVersion \geq 2.4. Originally it was written in degree. If used again, it must be written in radian or must be followed by a unit.

Value

Double Float Value

Default

no default

ESRF_ID01_Goniometer_Chi

Description

Chi angle of the esrf id01 goniometer

Unit

degree^Σ (radian)

Value

Double Float Value

Default

no default

ESRF_ID01_Goniometer_Phi

Description

Phi angle of the esrf id01 goniometer

Unit

degree^Σ (radian)

^Σ This parameter is not written any more in SaxsDataVersion \geq 2.4. Originally it was written in degree. If used again, it must be written in radian or must be followed by a unit.

Value

Double Float Value

Default

no default

ESRF Beamline Specific Keywords

The ESRF ID01 specific keywords in the above described form are no longer in use. They are replaced by informational beamline specific keywords of the type ESRF_<IDxx>_<SpecSession>_<MotorMnemonic>. The units are defined by the acquisition program.

Value

String Value

Version

2.30

ESRF_<IDxx>_<SpecSession>_<Mnemonic>

Description

String that describes the value of the parameter <Mnemonic> in the spec session <SpecSession> at the beamline <IDxx> at the ESRF. <Mnemonic> can be the name of variables, motor or counter mnemonics.

Default

no default

^Σ This parameter is not written any more in SaxsDataVersion≥2.4. Originally it was written in degree. If used again, it must be written in radian or must be followed by a unit.

Example

ESRF_ID01_PSIC_SAV = 10 ;

8. Backward Compatibility (EDF and SAXS)

This section describes keywords that are only used for backward compatibility and which might disappear in the future.

The following keywords are not required any more and can be omitted if the file will not be read by old software.

Keywords

HeaderID

Description

Data block header identification starting with *EH:* and consisting of three 6 digits long unsigned decimal numbers separated by colons. Only the first number is used and larger than zero. The headers are numbered in ascending order starting with 1.

Value

Syntax

EH:<header_id>:000000:000000, with <header_id> = 1, 2, ...

Example

The first header in the data file looks like this:

HeaderID = EH:000001:000000:000000 ;

Size

Description

Size of the binary section after the header in bytes.

Value

This keyword duplicates the value after Default

no default

Version

2.30 (redefined)

EDF_BinarySize.

Image

Description

This value duplicates the sequence number of the data block identifier (EDF_DataBlockID) for the case that the data block identifier ends with "Image.Psd"

Value

Syntax

String Value ("All") or Long Integer Value ("1"). All data blocks with valid data have a Long Integer Value.

Example

Image = 1;

Keywords in General Header

The keys "DataKey-<memory>" are used to redefine "<class>.<memory>" identifiers. "DataKey-1" corresponds always to "Image.Psd". The defaults of "DataKey-2", "DataKey-3" etc. correspond always to "Image.<memory>". These keywords are only used in the general header.

DataKey_<memory>

Description

"<class>.<memory>" of this item

Value

String Value

Default

DataKey-1 => Image

Version

2.30 (redefined)

9. History

Version < 1.00

Historic version with multiple headers, before and after the binary data, not restricted to 512 byte blocks (before 1995)

Version 1.00

Version with a single header preceding the binary data, usually restricted to 512 byte blocks (until February 1998)

Version 2.00

Totally renewed version as described in this document

Version 2.10

New keywords: Intensity0, Intensity0Monitor, Intensity1, Intensity1Monitor, AnodeCounts, AnodeCountsMonitor, ExposureTime, ExposureTimeMonitor, ESRF_ID01_TDC_ResolutionMode, ESRF_ID01_TDC_Resolution, ESRF_ID01_TDC_Offset, ESRF_ID01_TDC_Timeout, ESRF_ID01_Goniometer_Theta, ESRF_ID01_Goniometer_Chi, ESRF_ID01_Goniometer_Chi, ESRF_ID01_Goniometer_Phi

These keywords are not used for SaxsDataVersion>=2.40.

Version 2.11

History of command lines

Version 2.20

New keywords: DataValueOffset

Version 2.30

The only defined class is "Image", the only used instances are "Psd" and "Error". The block identifier has still the form <sequence>.<class>.<instance>[.<memory>].

Version 2.31

2004-09-25

New keyword: ProjectionType

Version 2.40

2004-10-04

From now on all angles that are written into the header can be followed by a unit in the form "<value>_deg" or "<value>_rad", e.g. 32.5_rad. Other units must not be used. If the unit is missing the unit radian is used. This contradicts the earlier definition where the angular unit was degree. This redefinition affects especially the keys: DetectorRotation_1, DetectorRotation_2, DetectorRotation_3. But because these keys were never written into the header in earlier versions there is no danger of confusion. If necessary the key SaxsDataVersion can be used to distinguish between both definitions: SaxsDataVersion>=2.40: all angles are measured in rad.

Version 2.41

2007-06-15

The standard start pattern is an opening curly brace without leading line feed (adaptation to KLORA format).

10. Appendix

Example of a General Header

Words in italics are historical keywords, that are only written for backward compatibility. Underlined values are only written for backward compatibility and will be replaced by their alias names.

```
{  
EDF_DataFormatVersion = 2.30 ;  
EDF_DataBlocks = 9 ;  
EDF_BlockBoundary = 512 ;  
  
}
```

Example of a Data Block Header

Words in italics are historical keywords, that are only written for backward compatibility. Underlined values are only written for backward compatibility and will be replaced by their alias name.

```
{  
EDF_DataBlockID = 1.Image.Psd ;  
EDF_BinarySize = 1048576 ;  
ByteOrder = LowByteFirst ;  
Center_1 = 269 ;  
Center_2 = 268 ;  
Compression = None ;  
DataType = FloatValue ;  
DDummy = 0.1 ;
```



```
Dim_1 = 512 ;  
Dim_2 = 512 ;  
Dummy = -1 ;  
HeaderID = EH:000001:000000:000000 ;  
Image = 1 ;  
Offset_1 = 0 ;  
Offset_2 = 0 ;  
Psize_1 = 0.000343 ;  
Psize_2 = 0.000337 ;  
RasterOrientation = 1 ;  
SampleDistance = 9.82514 ;  
SaxsDataVersion = 1.0 ;  
Size = 1048576 ;  
Title = vacuum setup ;  
WaveLength = 9.90376e-11 ;
```

```
}
```

```
<binary data follows here>
```

Example of a Data Block Header for Raw Data

Words in italics are historical keywords, that are only written for backward compatibility. Underlined values are only written for backward compatibility and will be replaced by their alias name.

```
{
```

```
EDF_DataBlockID = 1.Image.Psd ;
```

EDF_BinarySize = 1048576 ;
ByteOrder = HighByteFirst ;
Center_1 = 269 ;
Center_2 = 268 ;
Compression = None ;
DataType = UnsignedInteger ;
DetectorName = two dimensional delay line detector (IF = 176, SN = 3) ;
DetectorPosition = 9.10013 ;
Dim_1 = 512 ;
Dim_2 = 512 ;
Dummy = -1 ;
HeaderID = EH:000001:000000:000000 ;
HMDeltaTime = 0.006 ;
HMFile = /scratch/data/com38/com38_001-001 ;
HMFrame = 1 ;
HMStartTime = Wed Dec 4 02:51:48 1996 ;
HS32C01 = 59807 ;
HS32C02 = 3562 ;
HS32C03 = 2228 ;
HS32C04 = 8743 ;
HS32C05 = 54374 ;
HS32C06 = 2150 ;
HS32C07 = 57630 ;
HS32C08 = 17714 ;
HS32C09 = 54374 ;
HS32C10 = 28 ;
HS32C11 = 0 ;
HS32C12 = 0 ;
HS32C13 = 726006 ;
HS32C14 = 355 ;
HS32C15 = 1.05002e+08 ;
HS32C16 = 51268 ;

HS32C17 = 0 ;
HS32C18 = 0 ;
HS32C19 = 0 ;
HS32C20 = 0 ;
HS32C21 = 0 ;
HS32C22 = 20095 ;
HS32C23 = 1.07518e+08 ;
HS32C24 = 1.07518e+08 ;
HS32C25 = 0 ;
HS32C26 = 0 ;
HS32C27 = 0 ;
HS32C28 = 0 ;
HS32C29 = 0 ;
HS32C30 = 0 ;
HS32C31 = 0 ;
HS32C32 = 0 ;
HS32Depth = 26.8074 ;
HS32F01 = 7.59e+07 ;
HS32F02 = 7.27e+07 ;
HS32F03 = 3.51228e+07 ;
HS32F04 = 4.0644e+08 ;
HS32F05 = 9.78206e+06 ;
HS32F06 = 1.05443e+11 ;
HS32F07 = 1.35616e+06 ;
HS32F08 = 3.56277e+11 ;
HS32F09 = 9.78206e+06 ;
HS32F10 = 2.00337e+10 ;
HS32F11 = 1 ;
HS32F12 = 1 ;
HS32F13 = 1 ;
HS32F14 = 2048 ;
HS32F15 = 1e-06 ;

HS32F16 = 0.002048 ;

HS32F17 = 1 ;

HS32F18 = 1 ;

HS32F19 = 1 ;

HS32F20 = 1 ;

HS32F21 = 1 ;

HS32F22 = 0.01 ;

HS32F23 = 1 ;

HS32F24 = 0.0005 ;

HS32F25 = 0 ;

HS32F26 = 0 ;

HS32F27 = 0 ;

HS32F28 = 0 ;

HS32F29 = 0 ;

HS32F30 = 0 ;

HS32F31 = 0 ;

HS32F32 = 0 ;

HS32Len = 32 ;

HS32N01 = PIN1 ;

HS32N02 = PIN2 ;

HS32N03 = PIN3 ;

HS32N04 = PIN41 ;

HS32N05 = PIN42 ;

HS32N06 = PIN5 ;

HS32N07 = PIN6 ;

HS32N08 = PIN7 ;

HS32N09 = I0 ;

HS32N10 = I02 ;

HS32N11 = I1 ;

HS32N12 = I12 ;

HS32N13 = anode ;

HS32N14 = anode2 ;

HS32N15 = time ;
HS32N16 = time2 ;
HS32N17 = bad ;
HS32N18 = bad ;
HS32N19 = bad ;
HS32N20 = bad ;
HS32N21 = bad ;
HS32N22 = LINKAM ;
HS32N23 = vfc27 ;
HS32N24 = thc2 ;
HS32N25 = 0 ;
HS32N26 = ;
HS32N27 = ;
HS32N28 = ;
HS32N29 = ;
HS32N30 = ;
HS32N31 = ;
HS32N32 = ;
HS32Z01 = 41.01 ;
HS32Z02 = 14.16 ;
HS32Z03 = 19.82 ;
HS32Z04 = 82.31 ;
HS32Z05 = 416 ;
HS32Z06 = 20.8 ;
HS32Z07 = 549.4 ;
HS32Z08 = 168.6 ;
HS32Z09 = 416 ;
HS32Z10 = 0.203125 ;
HS32Z11 = 0 ;
HS32Z12 = 0 ;
HS32Z13 = 0 ;
HS32Z14 = 0 ;

HS32Z15 = 0 ;
HS32Z16 = 0 ;
HS32Z17 = 0 ;
HS32Z18 = 0 ;
HS32Z19 = 0 ;
HS32Z20 = 0 ;
HS32Z21 = 0 ;
HS32Z22 = 20050 ;
HS32Z23 = 0 ;
HS32Z24 = -4000 ;
HS32Z25 = 0 ;
HS32Z26 = 0 ;
HS32Z27 = 0 ;
HS32Z28 = 0 ;
HS32Z29 = 0 ;
HS32Z30 = 0 ;
HS32Z31 = 0 ;
HS32Z32 = 0 ;
HSAnode = 13 ;
HSAnodeS = 14 ;
HSI0 = 5 ;
HSI0S = 10 ;
HSI1 = 7 ;
HSI1S = 0 ;
HSTime = 15 ;
HSTimeS = 16 ;
Image = 1 ;
MachineInfo = " Ie=165.58mA,gap46=25.54mm,taper46=
0.00mm,gap26=20.31mm,taper26= 0.01mm" ;
Offset_1 = 0 ;
Offset_2 = 0 ;
OpticsInfo = optics ;

```
Psize_1 = 0.000343 ;  
Psize_2 = 0.000337 ;  
RasterOrientation = 1 ;  
SampleDistance = 9.82514 ;  
SaxsDataVersion = 1.0 ;  
Size = 1048576 ;  
StationInfo = id2 ;  
ExperimentInfo = detector with 2.02% R14 + 20.1% C2H6 + QS Xe(Air  
Liquide ;  
Title = vacuum setup ;  
WaveLength = 9.90376e-11 ;
```

```
}
```

```
<binary data follows here>
```