

ALBA timing control

21st Tango collaboration meeting

May 13 and 14, 2009.

Ramon Suñé
Jairo Moldes
Computing division
ALBA

- Introduction
 - Hardware
 - Software
 - TODO
- 

The Fan Out modules distribute the events over the timing network.

(events) that are sent over the same channel.

The Event Receivers decode the digital stream and will react to certain pre-programmed events producing an output. The characteristic of this output can be also pre-programmed.

* All the events are transmitted sharing the same channel. The Event Stream Rate is synchronous with the RF frequency.

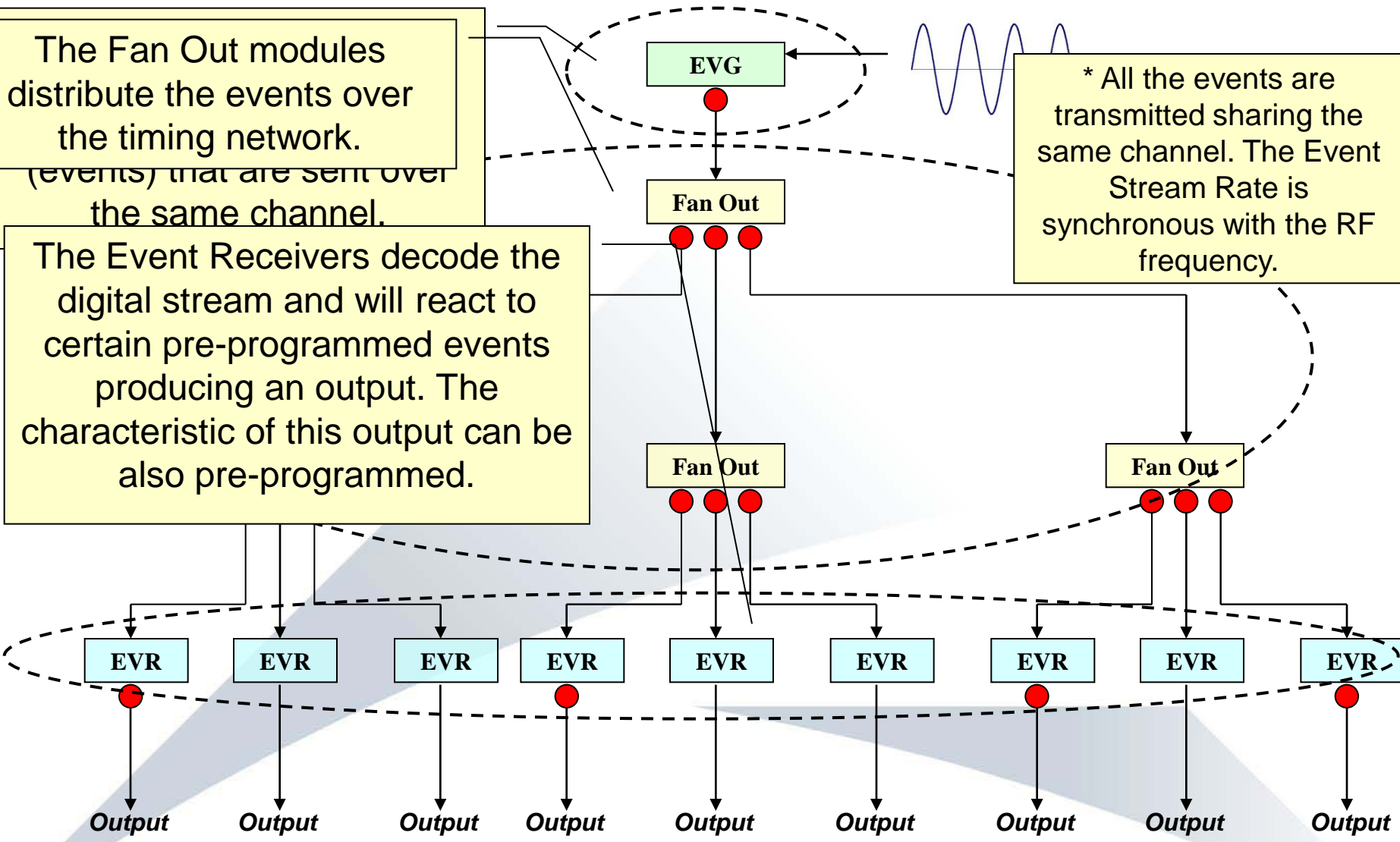

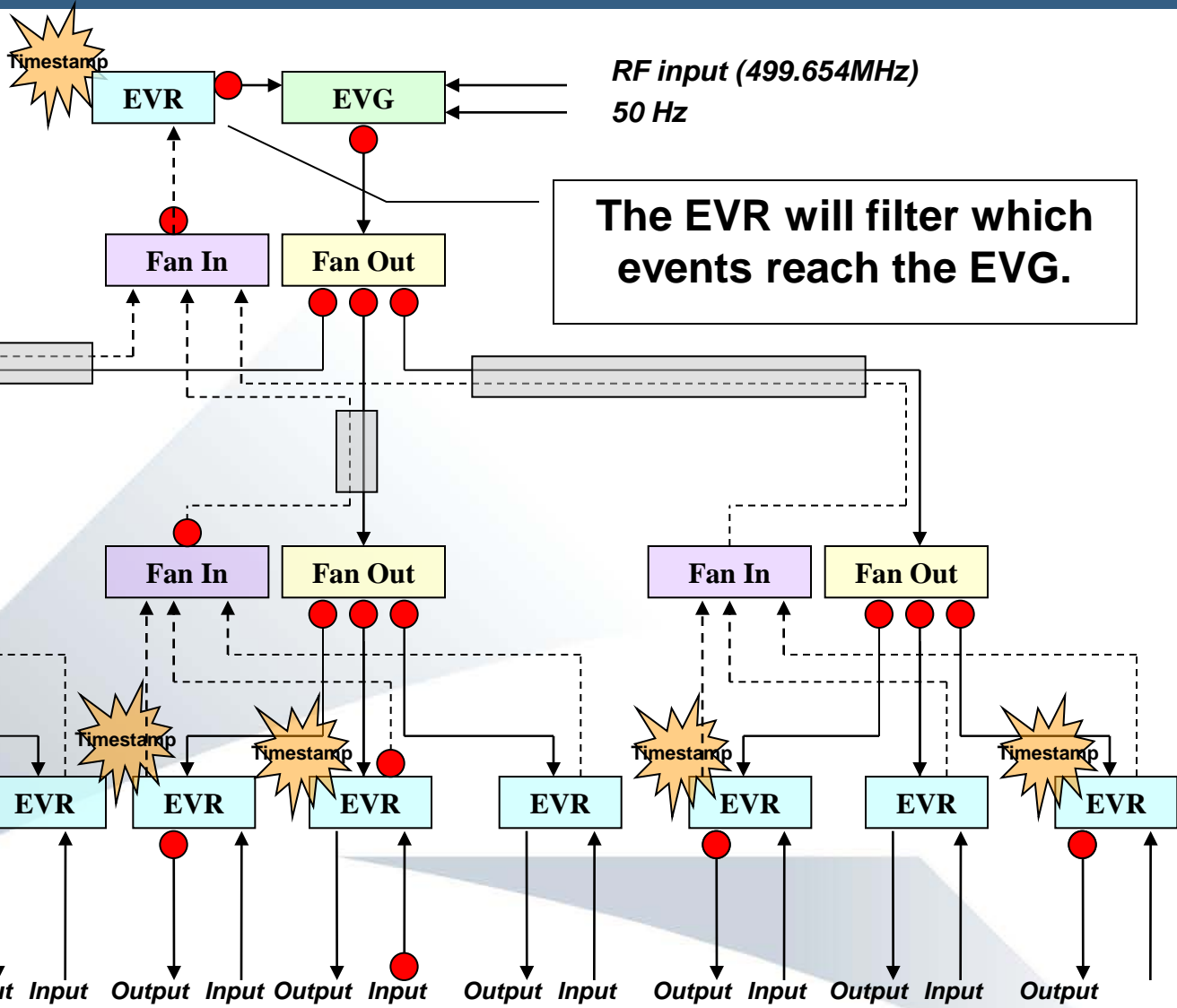

- Final objective: make user's life easier
 - Huge amount of output signals to configure and control (~800)
 - Each signal may have different characteristics
 - Allow the flexibility given by the hardware, but hide it's complexity
- Event based system
- EVG
 - 1 unit
 - Sends: 1 event / 8 bit distributed bus @ configurable clock rate (internal or external)
- EVRs
 - 101 units
 - Responds to events or dbus received generating an output signal
 - Reacts on IN signals generating an event or as if an event was received
- Fanouts
 - 32 units
 - Hw components for distributing the optical signal upstream/downstream
 - Minimal software control (enable/disable, status, clear flags, ...)

- Event + DBus sent every $8.0053983356 \text{ ns} = 1 / (499.654\text{MHz} / 4)$
- Events: 8 bits code. 256 events (8 of them reserved)
- DBus: may transport a “signal” per bit or a byte of data
- Events sent on:
 - Counter (internal / external)
 - External signal in
 - Upstream events: this will be used for Fast Interlock
 - An event may be fired on raising AC mains voltage synchronization
 - Software request
- 2 Events sequencer fired on:
 - Counter
 - Software

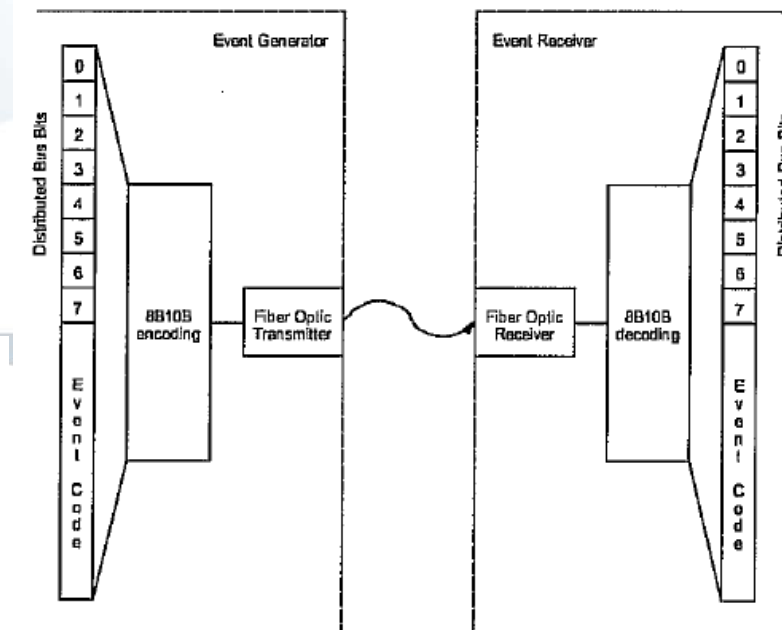
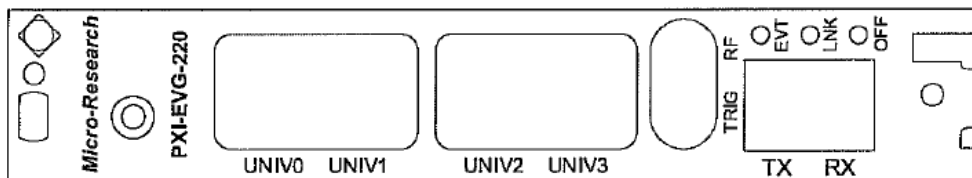

- On event receiving, it is decoded and the associated actions are performed
- Usual action: generate a pulse on one of the outputs
- Other actions:
 - log event
 - save event on FIFO
 - forward downstream
 - heartbeat
- 2 external hardware inputs that will (will be used for fast interlock):
 - generate an event to be treated internally as any other event, and/or
 - make the receiver send an event downstream (logically upstream)

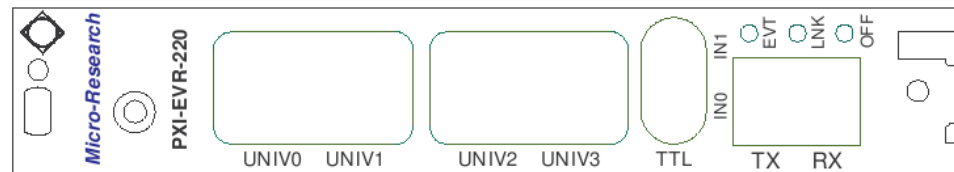
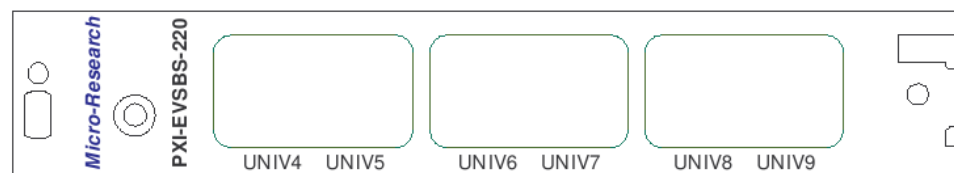
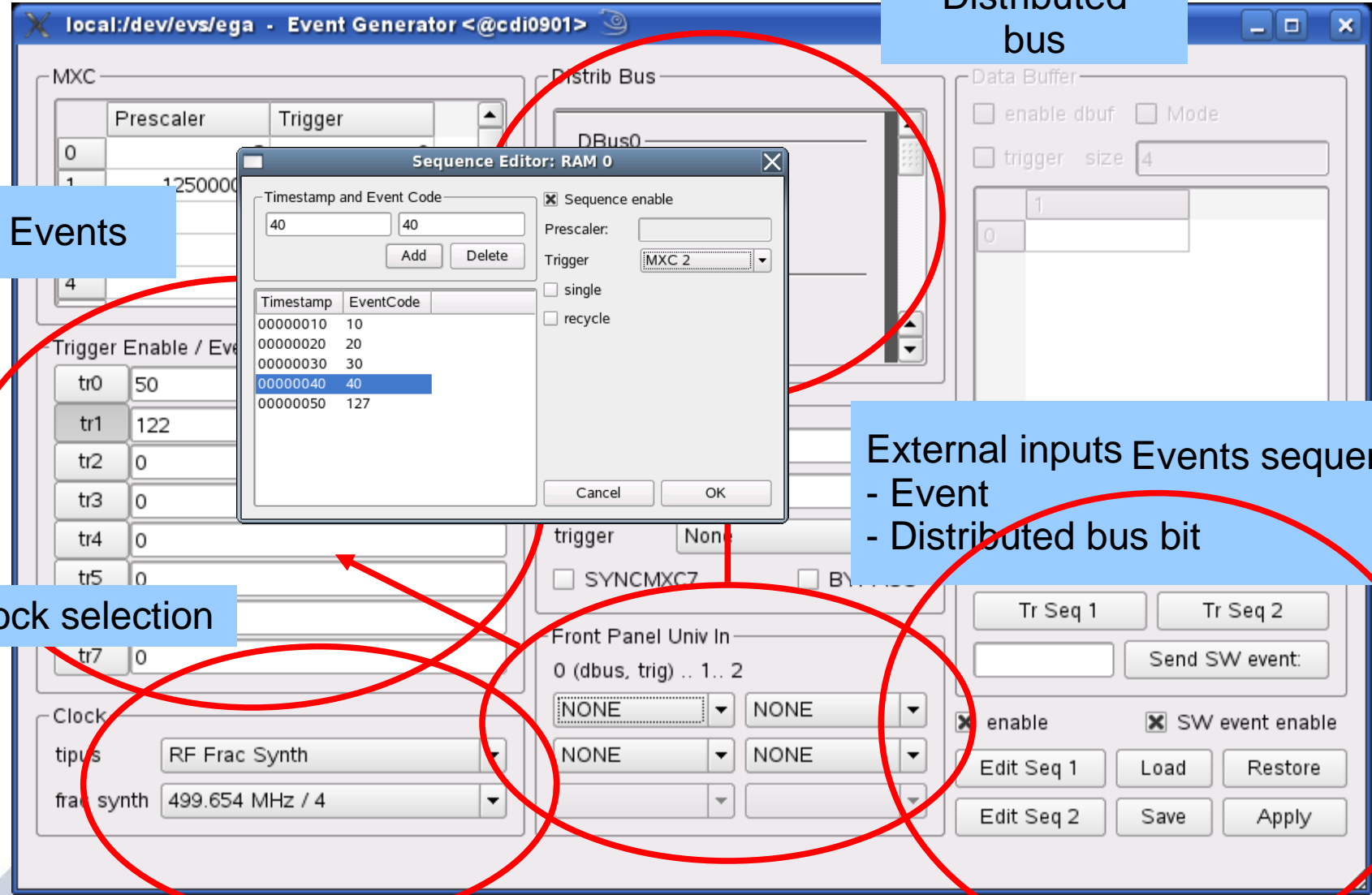

Figure 4: Event Receiver Front Panel



- What we have:
 - Linux 2.6 driver for cPCI boards EVR-230, EVG-230 (C)
 - EVG and EVR APIs from MRF slightly modified at ALBA to provide extra functions (C)
 - Home made Fanout API (C++)
 - EVG, EVR and Fanout C/C++ APIs translated to python
 - Tango device servers for EVG, EVR and Fanout (python)
 - GUI for EVG and EVR developed using PyQt
- TODO in the near future:
 - Centralized timing device server and GUI
 - Injection timing GUI

Distributed bus



Events

Clock selection

External inputs Events sequence
- Event
- Distributed bus bit

Sequence Editor: RAM 0

Timestamp and Event Code

40 40

Add Delete

Timestamp	EventCode
00000010	10
00000020	20
00000030	30
00000040	40
00000050	127

Sequence enable

Prescaler: []

Trigger: [MXC 2]

single recycle

Cancel OK

Data Buffer

enable dbuf Mode []

trigger size [4]

1
0

MXC

Prescaler	Trigger
0	
1	125000
4	

Trigger Enable / Ev

tr	Value
tr0	50
tr1	122
tr2	0
tr3	0
tr4	0
tr5	0
tr7	0

Distrib Bus

DBus0

trigger [None]

SYNCMXC7

Front Panel Univ In

0 (dbus, trig) .. 1.. 2

[None] [None]

[None] [None]

[None] [None]

[None] [None]

[None] [None]

[None] [None]

Tr Seq 1 Tr Seq 2

Send SW event: []

enable SW event enable

Edit Seq 1 Load Restore

Edit Seq 2 Save Apply

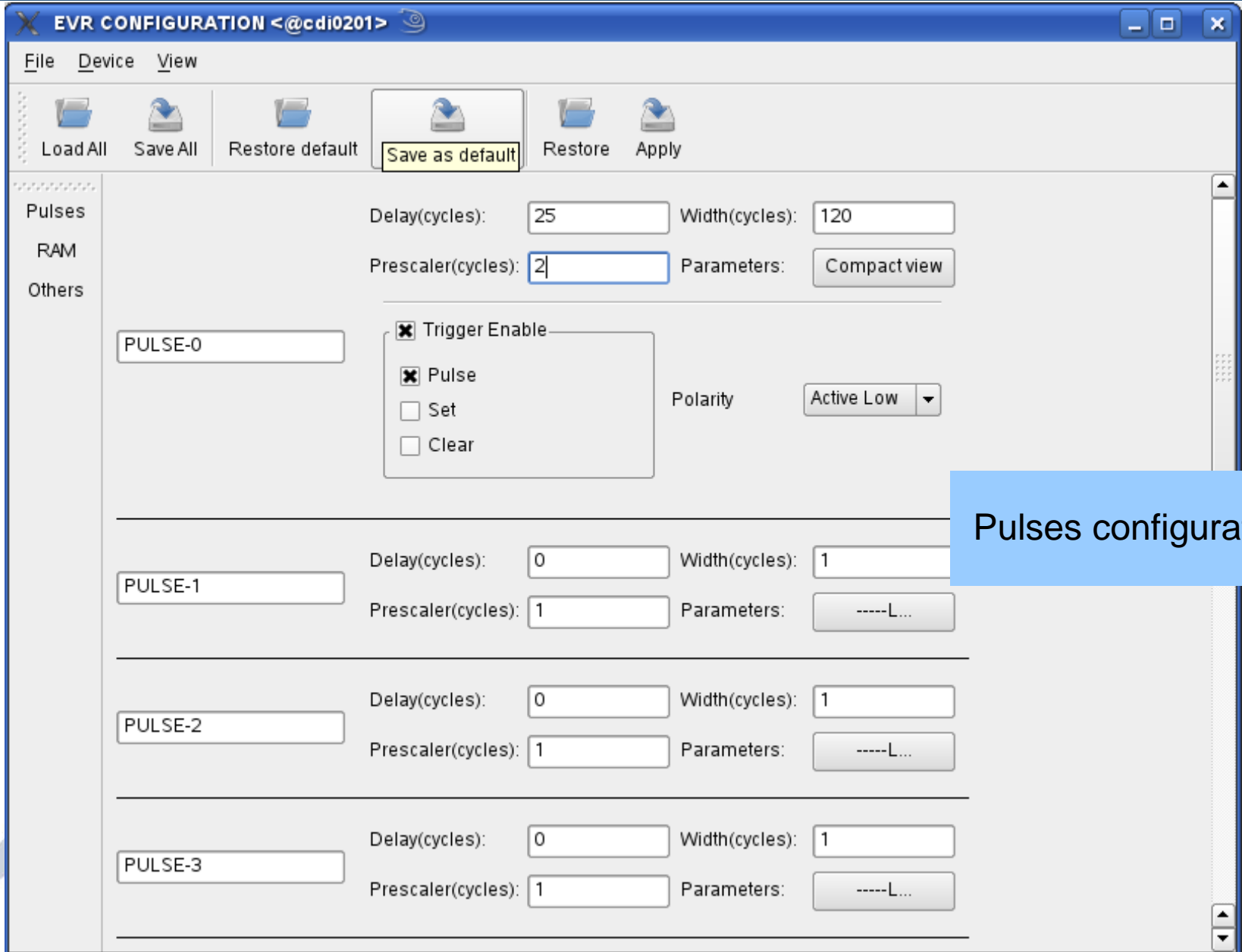

The screenshot shows the 'EVR CONFIGURATION' window with the following settings:

- Toolbar:** Load All, Save All, Restore default, Save as default (highlighted), Restore, Apply.
- Left Panel:** Pulses, RAM, Others.
- PULSE-0 Configuration:**
 - Delay(cycles): 25
 - Width(cycles): 120
 - Prescaler(cycles): 2
 - Parameters: Compact view
 - Trigger Enable:
 - Pulse:
 - Set:
 - Clear:
 - Polarity: Active Low
- PULSE-1 Configuration:**
 - Delay(cycles): 0
 - Width(cycles): 1
 - Prescaler(cycles): 1
 - Parameters: -----L...
- PULSE-2 Configuration:**
 - Delay(cycles): 0
 - Width(cycles): 1
 - Prescaler(cycles): 1
 - Parameters: -----L...
- PULSE-3 Configuration:**
 - Delay(cycles): 0
 - Width(cycles): 1
 - Prescaler(cycles): 1
 - Parameters: -----L...

Pulses configuration

EVR CONFIGURATION <@cdi0201>

File Device View

Load All Save All Restore default Save as default Restore At...

	Id	Name	Summary
Pulses	033	EV-33	T(PULSE-0) [SaveEvent] [LedEvent] [ForwardEvent] [StopEvent]
RAM			
Others			

EV-33 (event 33)

Trigger	Set	Clear
<input checked="" type="checkbox"/> PULSE-0	<input type="checkbox"/> (PULSE-0)	<input type="checkbox"/> (PULSE-0)
<input type="checkbox"/> (PULSE-1)	<input type="checkbox"/> (PULSE-1)	<input type="checkbox"/> (PULSE-1)
<input type="checkbox"/> (PULSE-2)	<input type="checkbox"/> (PULSE-2)	<input type="checkbox"/> (PULSE-2)
<input type="checkbox"/> (PULSE-3)	<input type="checkbox"/> (PULSE-3)	<input type="checkbox"/> (PULSE-3)
<input type="checkbox"/> (PULSE-4)	<input type="checkbox"/> (PULSE-4)	<input type="checkbox"/> (PULSE-4)
<input type="checkbox"/> (PULSE-5)	<input type="checkbox"/> (PULSE-5)	<input type="checkbox"/> (PULSE-5)
<input type="checkbox"/> (PULSE-6)	<input type="checkbox"/> (PULSE-6)	<input type="checkbox"/> (PULSE-6)
<input type="checkbox"/> (PULSE-7)	<input type="checkbox"/> (PULSE-7)	<input type="checkbox"/> (PULSE-7)
<input type="checkbox"/> (PULSE-8)	<input type="checkbox"/> (PULSE-8)	<input type="checkbox"/> (PULSE-8)
<input type="checkbox"/> (PULSE-9)	<input type="checkbox"/> (PULSE-9)	<input type="checkbox"/> (PULSE-9)

Flags

- LED Event
- Save Event
- Forward Event
- Stop Event (FIFO)
- Heartbeat Event
- Latch Timestamp
- Resetpresc Event
- Timestamp Reset
- Timestamp CLK
- Seconds 0
- Seconds 1

Add Delete Selected

Actions for event

The screenshot shows the EVR CONFIGURATION GUI with the following settings:

- TTLIN0:** External Event: 55, Backward Event: NONE
- TTLIN1:** External Event: NONE, Backward Event: 62
- Counters:** Counter 0 (cycles): 155, Counter 1 (cycles): 0, Counter 2 (cycles): 0
- Outputs:** UNIV0: PULSE-0 (pulse 0), UNIV1: DBUS 1, UNIV2: COUNTER 0, UNIV3: LOW, UNIV4: LOW, UNIV5: LOW, UNIV6: LOW, UNIV7: LOW, UNIV8: LOW, UNIV9: LOW

A blue box in the bottom right corner contains the following text:

- Outputs
- External event
- Backward event
- Counters

- Control over all channels on all receivers
- Global event clock configuration
- Global heartbeat application:
 - Direct heartbeat
 - Reverse heartbeat
- Global Timestamp:
 - Configuration
 - Data log recovery

- Access to all the central timing DS using a friendly tree like presentation

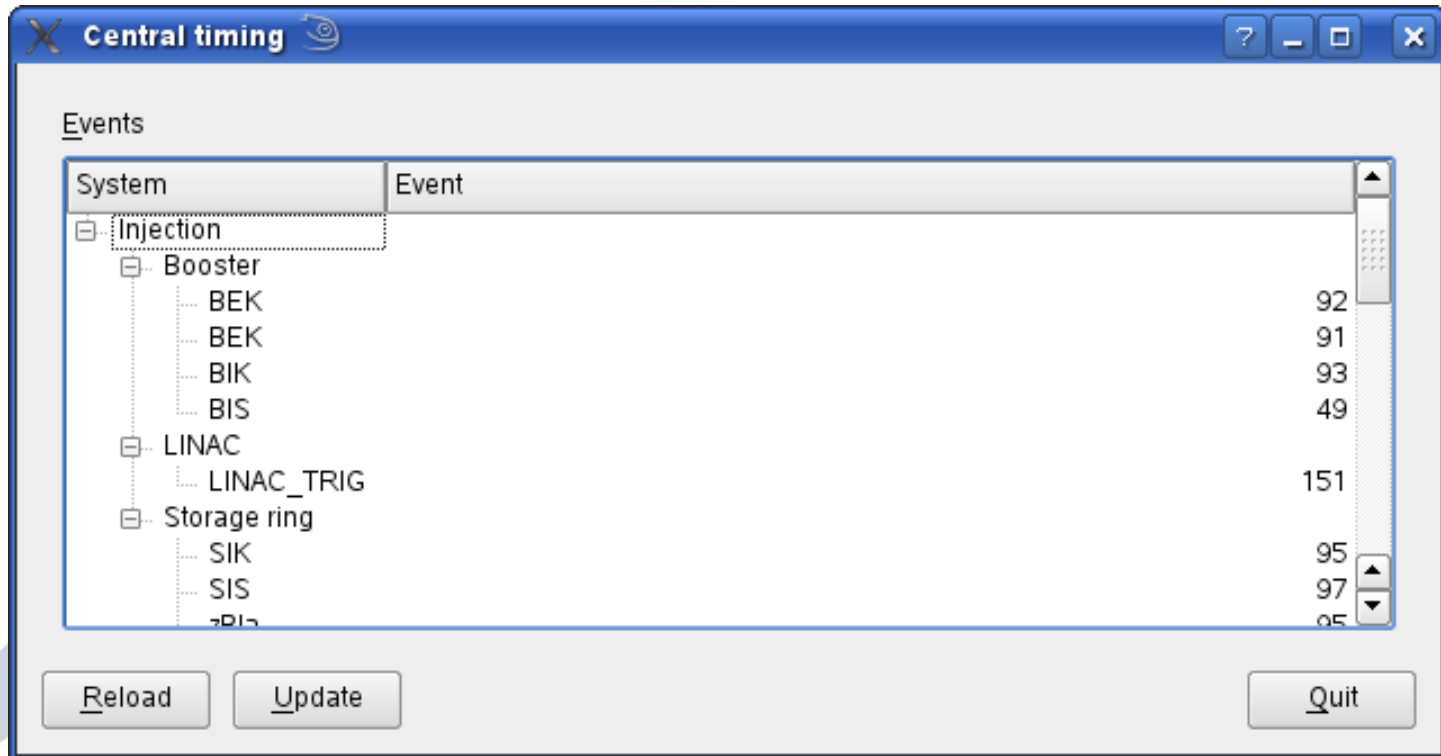

The screenshot displays the 'ALBA MAIN INJECTION' control window. It is divided into several sections:

- MAIN INJECTION:** Contains input fields for 'RATE' (3 Hz) and 'CURRENT' (70 mA). Below these is a dropdown menu for 'INJECTION MODE' with options: 'Multi Bunch 56 (112ns)', 'Multi Bunch 120 (240ns)', 'Single Bunch', and '...'. Further down are fields for '# TRAINS' (3), '# SB bunches' (1-16), and 'SB interval' (2ns-128ns). A button 'Edit Filling Patters' is located below these fields. At the bottom of this section are 'START INJECTION' and 'STOP TRIGGER' buttons.
- STATUS:** A vertical column of read-only status indicators: 'Mode', 'RF frequency (Hz)', 'LINAC x injection (nC)', 'Booster x injection(mA)', 'SR x injection (mA)', 'Booster Efficiency (%)', 'SR Efficiency (%)', and 'Stored Current (mA)'.
- SUB-SYSTEM:** A row of three buttons: 'LINAC', 'PULSED / RAMPING', and 'DIAGNOSTICS'.
- Footer:** Includes 'Save All', 'Load All', and 'Apply' buttons, and a 'Timing Status Flags: XXX YYY' indicator.

THALES PLCs

LINAC TIMING
⏏ ⏪ ⏩

📁 Load Table

🔄 Apply Table

💾 Save Table

File Path

File Name

Parameter	Description	Steps	Value	MAX	MIN
KA1D	KA1 delay (7b)	1us	xx	56us	1us
RFW1	RF1 duration	fixed	8912ns	8912ns	8912ns
KA2D	KA2 delay from KA1D (7b)	32ns	xx	4096ns	544ns
RF2D	RF2 delay from KA1D (8b)	8ns	xx	1920ns	512ns
EGD	eGun delay from KA1D (7b)	32ns	xx	4096ns	32ns
GPI	Interval between gun pulses (7b)	2ns	xx	256ns SBM / 1054 MBM	2ns SBM / 36ns MBM
GPN	Number of SBM pulses (4b)	1	xx	16	1
OML	MBM or SBM				

Timing Status Flags: **XXX** **YYY**

PULSED ELEMENTS / RAMPING

 - X

Graph View
Table View

Timing Pulses

3GeV

100MeV

INJECTION

BIS

BIK

RAMPING

BEND

Qs

RF

EXTRACTION

BEK

BES

SIK1

SIK2

SIS

SIK3

SIK4

Timing Status Flags: **XXX** **YYY**

DIAGNOSTICS
⏏

LINAC

<input checked="" type="checkbox"/> FCT01	delay	width	FORCE
<input checked="" type="checkbox"/> FCT02	delay	width	FORCE
<input checked="" type="checkbox"/> FCT03	delay	width	FORCE
<input type="checkbox"/> FCT04	delay	width	FORCE
<input checked="" type="checkbox"/> FS01	delay	width	FORCE
<input checked="" type="checkbox"/> FCT05	delay	width	FORCE
<input type="checkbox"/> FS02	delay	width	FORCE
<input checked="" type="checkbox"/> FCT06	delay	width	FORCE
<input checked="" type="checkbox"/> FS03	delay	width	FORCE
<input type="checkbox"/> BPM01	delay	width	FORCE
<input type="checkbox"/> BCM01	delay	width	FORCE

LTB

<input checked="" type="checkbox"/> AE1	delay	width	FORCE
<input type="checkbox"/> BPM01	delay	width	FORCE
<input checked="" type="checkbox"/> FS/OTR01	delay	width	FORCE
<input type="checkbox"/> VSR01	delay	width	FORCE
<input checked="" type="checkbox"/> FCT01	delay	width	FORCE
<input checked="" type="checkbox"/> BPM02	delay	width	FORCE
<input type="checkbox"/> FS/OTR02	delay	width	FORCE
<input type="checkbox"/> BCM01	delay	width	FORCE
<input checked="" type="checkbox"/> BPM03	delay	width	FORCE
<input type="checkbox"/> FS/OTR03	delay	width	FORCE

LiDia

<input checked="" type="checkbox"/> FCT01	delay	width	FORCE
<input checked="" type="checkbox"/> FS/OTR01	delay	width	FORCE
<input type="checkbox"/> BCM01	delay	width	FORCE

BOOSTER

<input checked="" type="checkbox"/> VSR02-01	delay	width	FORCE
<input type="checkbox"/> FS/OTR02-01	delay	width	FORCE
<input checked="" type="checkbox"/> FCT02-01	delay	width	FORCE
<input checked="" type="checkbox"/> DCCT03-01	delay	width	FORCE
<input type="checkbox"/> FS/OTR03-01	delay	width	FORCE
<input type="checkbox"/> VSR03-01	delay	width	FORCE
<input checked="" type="checkbox"/> DBPM03-01	delay	width	FORCE
<input checked="" type="checkbox"/> SEXC03-01	delay	width	FORCE
<input checked="" type="checkbox"/> AE03-01	delay	width	FORCE
<input type="checkbox"/> SMES04-01	delay	width	FORCE
<input checked="" type="checkbox"/> DBPM04-01	delay	width	FORCE
<input type="checkbox"/> FS/OTR04-01	delay	width	FORCE
<input type="checkbox"/> VSR04-01	delay	width	FORCE
<input type="checkbox"/> FSH04-01	delay	width	FORCE
<input type="checkbox"/> FS/OTR01-01	delay	width	FORCE
<input type="checkbox"/> Orbit BPMs	delay	width	FORCE

BTS

<input type="checkbox"/> BPM01	delay	width	FORCE
<input checked="" type="checkbox"/> FCT01	delay	width	FORCE
<input checked="" type="checkbox"/> FS/OTR01	delay	width	FORCE
<input type="checkbox"/> BPM02	delay	width	FORCE
<input type="checkbox"/> SRM01	delay	width	FORCE
<input type="checkbox"/> FS/OTR02	delay	width	FORCE
<input type="checkbox"/> BPM03	delay	width	FORCE
<input checked="" type="checkbox"/> SRM02	delay	width	FORCE
<input type="checkbox"/> FCT02	delay	width	FORCE
<input checked="" type="checkbox"/> BPM04	delay	width	FORCE
<input type="checkbox"/> FS/OTR04	delay	width	FORCE

STORAGE RING

<input type="checkbox"/> FSH16-01	delay	width	FORCE
<input type="checkbox"/> FSH16-02	delay	width	FORCE
<input checked="" type="checkbox"/> DBPM02-01	delay	width	FORCE
<input type="checkbox"/> FS02-01	delay	width	FORCE
<input type="checkbox"/> DCCT02-01	delay	width	FORCE
<input checked="" type="checkbox"/> AE02-01	delay	width	FORCE
<input type="checkbox"/> FCT02-01	delay	width	FORCE
<input checked="" type="checkbox"/> SEXC02-01	delay	width	FORCE
<input checked="" type="checkbox"/> DBPM02-02	delay	width	FORCE
<input checked="" type="checkbox"/> DBPM03-01	delay	width	FORCE
<input type="checkbox"/> FFKH03-01	delay	width	FORCE
<input type="checkbox"/> FFKV03-01	delay	width	FORCE
<input type="checkbox"/> FS04-01	delay	width	FORCE
<input type="checkbox"/> FS08-01	delay	width	FORCE
<input type="checkbox"/> FS12-01	delay	width	FORCE
<input type="checkbox"/> Orbit BPMs	delay	width	FORCE

REFERENCE TRIGGER FORCE ALL

On LINAC_TRIG
On Ashynchronous trigger
...

Booster BPMs
SetTimeAll

Storage Ring BPMs
SetTimeAll

Load Table Save Table

Apply Table File Path

File Name

Timing Status Flags: **XXX** **YYY**